

# intertextile

SHANGHAI apparel fabrics

中国国际纺织面料及辅料(春夏)博览会  
China International Trade Fair for Apparel Fabrics  
and Accessories – Spring Edition

2025.3.11 – 13

国家会展中心 (上海)  
National Exhibition and Convention  
Center (Shanghai), China

## 同期活动

Fringe Programme



研讨会日程  
Seminar schedule



 messe frankfurt

# 同期活动场地

## Fringe Programme Venues

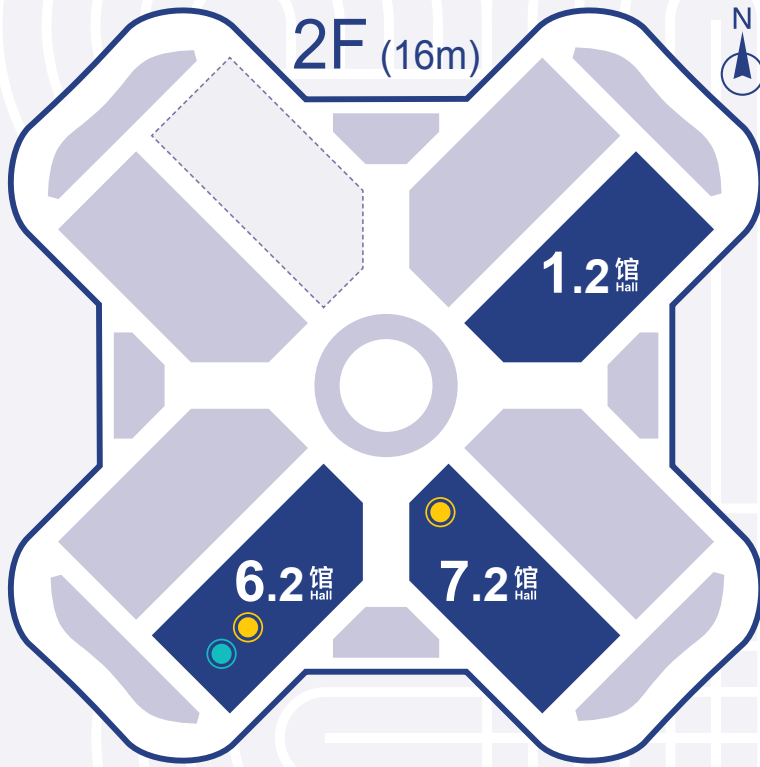

- 流行趋势 Trend Forum
- 新技术创新空间 Innotex Space
- 可持续创新专区 Sustainable Zone
- 数字时尚创新空间 Digital Fashion Innovation Space
- 热点交流 Talking Point
- 对话纺织 Textile Dialogue
- 可持续发展论坛 Economy Talks

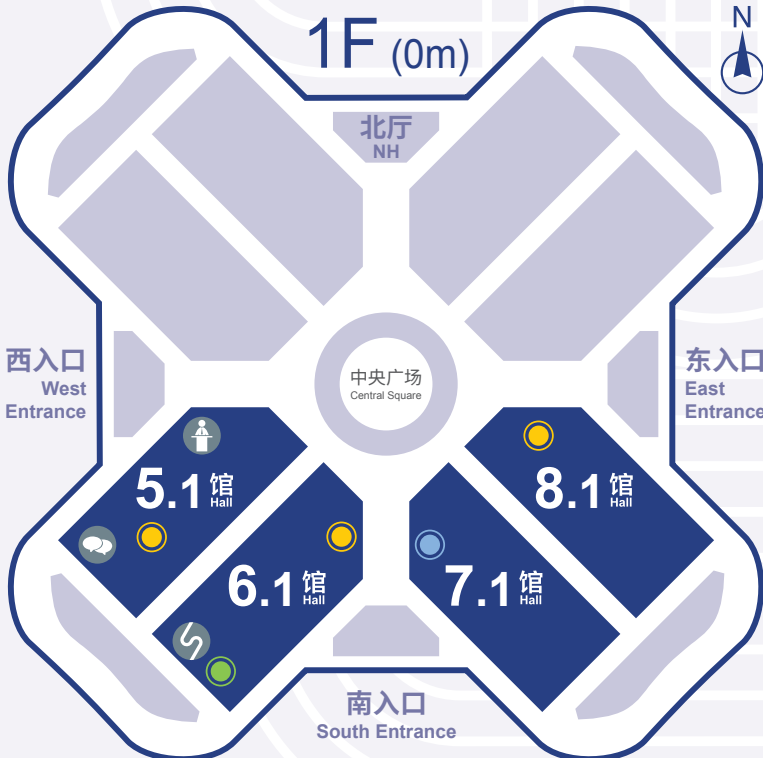

## 同期活动简介

### FRINGE PROGRAMME INTRODUCTION

中国国际纺织面料及辅料（春夏）博览会的同期活动将横跨两天展期，以4大主题分类，聚焦及塑造服装及纺织贸易行业的未来。我们邀来行业专家及企业参与近35场研讨会及论坛分享，为买家及观众带来行业见解。

The two-day fringe programme is categorised into four key themes that shape the future of the apparel and textile trade industry. Industry experts and the fair's exhibitors will conduct around 35 seminars, panel discussions and themed forums to provide the latest trends and insights for exhibitors and buyers.

#### 流行趋势

#### Design and Trends

国际知名的行业专家将进行多场研讨会及专题小组会议揭示2026春夏面料及色彩趋势。流行趋势发布区将通过面料展示与季节性潮流趋势全面揭示最新的设计趋势。

Internationally renowned industry specialists will offer various seminars and panel discussions to reveal the 2026SS fabrics and colour trends. Comprehensive Trend Forums revealing the latest in design trends through fabric displays and seasonal trend stories also feature throughout the fair.

- Intertextile 2026 春夏色彩、面料及流行趋势  
Intertextile Trends: Colours, Fabrics and Fashion Trends Spring-Summer 2026 P 06
- 2026 春夏中国纺织面料流行趋势论坛 2026SS Fabrics China Trend Forum P 08

#### 可持续发展议题

#### Econogy Talks

“Econogy”这个术语涵盖了在整个展会期间的所有可持续性主题活动。“Econogy”将经济和生态相结合，展示了可持续性对于企业的经济成功有多么关键。在“可持续发展论坛（Econogy Talks）”主题下，一系列研讨会和小组讨论将为您提供最新的可持续发展知识。

The term "Econogy" encompasses all the sustainability activities throughout the fair. Econogy summarises economy and ecology in one word and shows how crucial sustainability is for the economic success of a company today. Under the Econogy Talks name, a range of seminars and panel discussions will provide you with the latest sustainability knowledge.

- 全球纺织行业的循环经济——机遇与挑战  
Circularity in the Global Textile Industry - Opportunities and Challenges P 10
- Material X- 可持续未来材料研讨 Material X: NextGen Sustainable Solutions P 11
- 纺织服装行业产品碳足迹发布  
Release of Product Carbon Footprint in the Textile and Apparel Industry P 12

#### 市场信息及营销策略

#### Market Information & Business Strategies

在科技飞速发展的时代，面料不仅仅是服装的基础，更是时尚、功能与可持续发展的重要载体，特别是全球化背景下，人们更希望通过服装和面料传递文化认同和情感联系。面料的未来将如何与科技、设计和可持续发展相结合，色彩如何赋能面料创新？

In an era of rapid technological advancement, fabric is not just the foundation of clothing but also a crucial carrier of fashion, functionality, and sustainable development. Especially in the context of globalization, people increasingly hope to convey cultural identity and emotional connections through clothing and fabrics.

In the future, how will fabrics integrate with technology, design, and sustainability? And how can color empower fabric innovation?

- 面料创新的未来视野：创新、可持续与文化交融——中国流行面料 CLUB 面料创新探秘  
Future Perspectives on Fabric Innovation: Innovation, Sustainability, and Cultural Integration  
- Exploring Fabric Innovation with Fabrics China CLUB P 14
- 时尚行业数字化转型发展趋势与技术应对  
Digital Transformation Development Trend and Technology Response in the Fashion Industry P 16

#### 技术

#### Technology and Solutions

以纺织业的最新技术及创新科技为题的研讨会，研讨展商的最新科技及应用。2025国际纺织产业数字化应用趋势论坛聚焦纺织全流程数字化应用展开讨论。时尚行业数字化转型发展趋势论坛也将围绕数字技术应用实践，探讨行业未来发展方向，旨在提高纺织服装企业数字化转型能力。

Including sessions with latest technology and innovations and their applications as the key theme. The 2025 International Textile Industry Digital Application Trend Forum will explore Digital Applications across the entire textile process. The Digital Transformation Development Trend Forum will focus on digital technology applications, explore industry future trends, and enhance textile and apparel enterprises' digital capabilities.

- 创新铸就可持续未来——突破挑战、协同合作、深化影响  
Shaping the Future of Sustainability Through Innovation - Overcoming Obstacles,  
Fostering Cooperation, and Driving Impact P 17
- Intertextile FORUM 纺织论坛 数智融合创新，打开国际合作新局面  
Digital and Intelligent Integration and Innovation: Opening up a New Chapter for  
International Cooperation P 18
- 2025 国际纺织产业数字化应用趋势论坛  
2025 International Textile Industry Digital Application Trend Forum P 20

# 活动总览

## EVENT OVERVIEW

### 2025.3.11

时间 Time 地点 Venue	主题 Topic	企业 / 机构 Company / Institution	语言 Language
10:15 - 11:05 5.1-G148	中国传统色彩的色彩内涵和应用研究 Research on the Colour Connotation and Application of Traditional Chinese Colours	上海元彩科技有限公司 Coloro Co Ltd	普通话 * Mandarin*
10:20 - 10:50 5.1-K48	认识 GOTS - (由有机纤维制成的) 可持续和道德纺织品之源 Meet GOTS - Your Source for Sustainable and Ethical Textiles made with Organic Fibres	全球有机纺织品标准 (GOTS) Global Organic Textile Standard (GOTS)	普通话 * Mandarin*
10:30 - 12:30 6.1-E141	<b>论坛 Forum</b> 时尚行业数字化转型发展趋势与技术应对 Digital Transformation Development Trend and Technology Response in the Fashion Industry	中国纺织信息中心 China Textile Information Center	普通话 * Mandarin*
11:00 - 11:30 5.1-K48	OEKO-TEX® 新规解读与 TESTEX 创新产品引领纺织业可持续未来 Interpretation of OEKO-TEX® New Regulations and TESTEX New Products Leading the Sustainable Future of the Textile Industry	TESTEX 上海 TESTEX (Shanghai) Textile Testing Co Ltd	普通话 * Mandarin*
11:10 - 12:00 5.1-G148	Intertextile 2026 春夏色彩、面料及流行趋势 Intertextile Trends: Colours, Fabrics and Fashion Trends Spring-Summer 2026	Elementi Moda	英语 * English*
11:40 - 12:10 5.1-K48	材料很重要 Materials Matter	杭州爱达福乐检测技术有限公司 IDFL	普通话 * Mandarin*
12:05 - 12:55 5.1-G148	心灵: 混合平衡元素, 大胆打造出冲击心灵的 2026 春夏色彩 Mind: Blending the Balanced and Bold for a Mind-Bending Vision for Spring/Summer 2026	潘通色彩研究 Pantone Color Institute	英语 * English*
12:20 - 12:50 5.1-K48	OEKO-TEX® 2025 新规解析及 PFAS 合规管控指南 Analysis of OEKO-TEX® 2025 New Regulations and Compliance Management Guidelines for PFAS	海恩斯坦检测认证 (上海) 有限公司 Hohenstein Laboratories (Shanghai) Co Ltd	普通话 * Mandarin*
12:50 - 13:50 6.1-E141	质享人群崛起 新时代“讲究人”的家居趋势新洞见	小红书家纺及面料窗帘行业运营负责人 维莉 小红书商业家居行业 CBD 子歌	普通话 * Mandarin*
13:00 - 15:30 5.1-K48	<b>论坛 Forum</b> Material X - 可持续未来材料研讨 Material X: NextGen Sustainable Solutions	中国纺织工业联合会社会责任办公室 Office for Social Responsibility of China National Textile and Apparel Council	普通话 * Mandarin*
13:00 - 16:10 5.1-G148	<b>论坛 Forum</b> 2026 春夏中国纺织面料流行趋势论坛 2026SS Fabrics China Trend Forum	中国纺织信息中心 China Textile Information Center	普通话 * Mandarin*
14:00 - 17:20 6.1-E141	<b>论坛 Forum</b> 面料创新的未来视野: 创新、可持续与文化交融——中国流行面料 CLUB 面料创新探秘 Future Perspectives on Fabric Innovation: Innovation, Sustainability, and Cultural Integration - Exploring Fabric Innovation with Fabrics China CLUB	中国纺织信息中心 China Textile Information Center	普通话 * Mandarin*
15:35 - 16:05 5.1-K48	可持续化学品解决方案: ZDHC 化学物质零排放认证 Sustainable Chemical Management: ZDHC Zero Discharge of Hazardous Chemicals	北京爱科赛尔认证中心有限公司 Beijing ECOCERT Certification Centre Co Ltd	普通话 * Mandarin*
16:10 - 16:40 5.1-K48	欧盟可持续产品生态设计法规 (ESPR) 概览 EU Eco-design for Sustainable Products Regulation (ESPR) - Overview 产品碳足迹、碳中和——助力纺织行业可持续发展 Product Carbon Footprint, Carbon Neutrality - Empowering the Sustainable Development of the Textile Industry	天祥集团 Intertek	普通话 * Mandarin*
16:15 - 17:05 5.1-G148	WGSN 2026 春夏女装面料趋势预测 Women's Textiles Forecast S/S 26	WGSN	普通话 * Mandarin*
16:45 - 17:15 5.1-K48	欧美新法规环境下的供应链追溯 Supply Chain Traceability in the New Regulatory Landscape	TextileGenesis (简称 TG 公司, 为 Lectra 旗下企业) TextileGenesis, a Lectra company	普通话 * Mandarin*

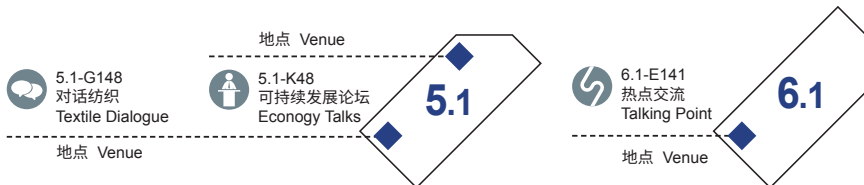

2025.3.12

时间 Time 地点 Venue	主题 Topic	企业 / 机构 Company / Institution	语言 Language
10:15 - 10:45 5.1-K48	中国纺织服装企业 ESG 转型实践与挑战 The Practice and Challenges of ESG Transformation of Chinese Textile and Apparel Enterprises	上海棉丰达商业管理有限公司 Shanghai Mianfengda Business Management Co Ltd	普通话 * Mandarin*
10:30 - 12:00 6.1-E141	<b>论坛 Forum</b> 纺织服装行业产品碳足迹发布 Release of Product Carbon Footprint in the Textile and Apparel Industry	中国纺织工业联合会社会责任办公室 Office for Social Responsibility of China National Textile and Apparel Council	普通话 * Mandarin*
10:30-13:00 5.1-G148	<b>论坛 Forum</b> 2026 春夏中国纺织面料流行趋势论坛 2026SS Fabrics China Trend Forum	中国纺织信息中心 China Textile Information Center	普通话 * Mandarin*
10:50 - 11:05 5.1-K48	协同创新——共建纺织产业永续未来 Advancing Sustainability in the Textile Industry - Collaborative Strategies for a Greener Future	香港纺织及成衣研发中心 HKRITA	普通话 * Mandarin*
11:15 - 12:45 5.1-K48	<b>论坛 Forum</b> 创新铸就可持续未来——突破挑战、协同合作、深化影响 Shaping the Future of Sustainability Through Innovation - Overcoming Obstacles, Fostering Cooperation, and Driving Impact	法兰克福展览（香港）有限公司 Messe Frankfurt (HK) Ltd	英语 * English*
12:10 - 12:40 6.1-E141	认证助力纺织服装企业创新 Certification Facilitates Innovation in Textile and Garment Enterprises	中联品检（北京）技术集团有限公司 United Testing Services (Beijing) Technology Group Co Ltd	普通话 * Mandarin*
12:55 - 13:25 5.1-K48	“regenagri” 再生 / 生态农业标准：纺织业可持续发展的新动力 regenagri: New Trend for Sustainable Development in the Textile Industry	世优认证（上海）有限公司 Control Union Certification (Shanghai) Co Ltd	普通话 * Mandarin*
13:10 - 14:00 5.1-G148	26 春夏女装趋势讲解 2026SS Women's Fashion Trend Forecast	PeclersParis	英语 * English*
13:30 - 16:00 6.1-E141	<b>论坛 Forum</b> 纺织论坛（春季） Intertextile Forum (Spring)	中国国际贸易促进委员会 纺织行业分会 The Sub-Council of Textile Industry of China Council for the Promotion of International Trade (CCPIT)	普通话 / 英语 * Mandarin / English*
13:35 - 14:05 5.1-K48	持续迭代的兰精创新纤维满足多元的市场需求 Continuously Iterating Lenzing Innovative Fibers to Meet Diverse Market Demands	兰精集团 Lenzing Group	普通话 * Mandarin*
14:05 - 16:30 5.1-G148	<b>论坛 Forum</b> 2025 国际纺织产业数字化应用趋势论坛 2025 International Textile Industry Digital Application Trend Forum	法兰克福展览（深圳）有限公司 Messe Frankfurt (Shenzhen) Co Ltd	普通话 * Mandarin*
14:15 - 14:45 5.1-K48	时尚行业 ESG 目标与可持续化学品管理 ESG Goals and Sustainable Chemical Management in the Fashion Industry	通标标准技术服务（上海）有限公司 SGS-CSTC Standards Technical Services (Shanghai) Co Ltd	普通话 * Mandarin*
14:55 - 16:25 5.1-K48	<b>论坛 Forum</b> 全球纺织行业的循环经济——机遇与挑战 Circularity in the Global Textile Industry - Opportunities and Challenges	法兰克福展览（香港）有限公司 Messe Frankfurt (HK) Ltd	英语 * English*
16:30 - 17:10 6.1-E141	科技赋能·新质丝绸 Technology Empowerment · New Quality Silk	浙江凯喜雅国际股份有限公司 Zhejiang Cathaya International Co Ltd	普通话 * Mandarin*
16:30 - 17:00 5.1-K48	以不变应万变——伊士曼 Naia™ Renew 短纤提供跨场景穿着的可持续解决方案 Versatility in Every Moment - Eastman Offers Sustainable Solutions for Cross-scenario Wear with Naia™ Renew Staple Fiber	伊士曼（中国）投资管理有限公司 Eastman Chemical (China) Co Ltd	普通话 * Mandarin*

\* 提供普通话 ↔ 英语同声传译

\* Mandarin Chinese ↔ English Simultaneous Interpretation will be provided

## 重点活动 – 流行趋势

### FEATURED EVENTS – DESIGN AND TRENDS

地点 Venue



5.1-E106  
流行趋势展示区  
Trend Forum

5.1

#### 流行趋势展示区 5.1-E106 Trend Forum 5.1-E106

潮流导向委员会自 1998 年成立，委员会各成员来自世界各地的时尚之都，遍布欧洲、亚洲及美国等全球主要成衣出口市场，并致力为设计师及纺织业专才提供宝贵的市场研究及推广工具，协助他们紧贴未来的时装潮流而进行设计及生产。每一季，委员会都会结合彼此的专业知识和地区实力，利用展商所提交的面料以鲜明的主题刻画未来潮流及时装材料趋势。

The *Directions* Trend Committee was established in 1998, with committee members coming from fashion capitals of the major export markets for international garment trade: New York, Milan, Paris and Tokyo. The committee provides an invaluable research and marketing tool to designers and garment professionals, helping them steer their designs and manufacturing processes in line with coming fashion seasons. Each season, they combine their expertise and local influences to come up with the themes that tell the story of tomorrow's apparel fabric trends and present at the Trend Forum through fabrics from exhibitors.

#### 2026 春夏季度主题：我 - 是我 Spring/Summer 2026 Seasonal theme: I-DENTITIES

在日益复杂的环境中，我们的世界也在迅速进化。然而，在这个漩涡之中，人类和物件的价值和个性却岿然不动。我们必须像呵护珍贵的幼苗般悉心栽培个性，在生活中寻求和谐健康的状态。

我们的生命蕴藏着无限的潜能和选择，犹如一个未被探索的宇宙。让我们拥抱自身的潜能，畅快淋漓地积极表达自我，迎接挑战！

这一季，人类的四种价值观将使我们能够展望未来：对功能性、经久耐用产品的需求；对恢复体力和重新掌控事物的渴望；对自我表达和接受独特性的需求；以及对借鉴过去塑造未来的渴望。

##### 四大主题：

• 简约 • 闯入 • 调皮 • 自由

Amidst increasing complexity, our world is struggling for rapid evolution. Yet, within this whirlwind, the values and identities of humans and objects stand steadfast. We must nurture individuality like precious seedlings, seeking a harmonious state of wellness in our lives.

Within our beings lie infinite potential and choices; a universe unexplored. Let us embrace our own potential, positively express our identities with unbridled joy, and rise to the challenge!

##### Four themes will be presented:

• SIMPLE • HACKING • MISCHIEF • FREEDOM

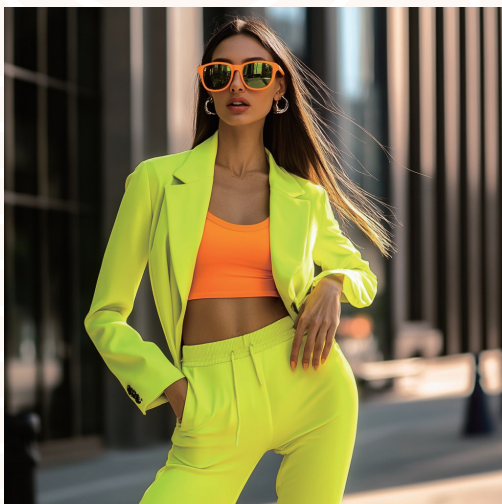

# 重点活动 – 流行趋势

## FEATURED EVENTS – DESIGN AND TRENDS



### Intertextile 流行趋势讲解 Intertextile Trend Introduction



2026 年春夏潮流趋势之首席设计师是来自意大利 Elementi Moda 的 Ornella Bignami 女士, 她将全面介绍 Intertextile 流行趋势, 包括各种面料的设计与潮流趋势。

The designer of the Intertextile *Directions* Trend Forum for Spring / Summer 2026 is Ms Ornella Bignami from Elementi Moda in Italy, who will introduce the Intertextile Trends, the latest design trends and seasonal trend stories.

### 2025.3.11

11:10 - 12:00 5.1-G148	Intertextile 2026 春夏色彩、面料及流行趋势 Intertextile Trends: Colours, Fabrics and Fashion Trends Spring-Summer 2026
13:00 - 13:30 5.1-E106	流行趋势讲解 – 第一节 Trend Forum Introduction Tour - Session 1
15:30 - 16:00 5.1-E106	流行趋势讲解 – 第二节 Trend Forum Introduction Tour - Session 2

### 2025.3.12

11:00 - 11:30 5.1-E106	流行趋势讲解 – 第三节 Trend Forum Introduction Tour - Session 3
---------------------------	---

\* 提供普通话 ↔ 英语同声传译  
\* Mandarin Chinese ↔ English Simultaneous Interpretation will be provided for all above sessions.



# 重点活动 – 流行趋势

## FEATURED EVENTS – DESIGN AND TRENDS

2026 春夏中国纺织面料流行趋势论坛  
2026SS Fabrics China Trend Forum

论坛  
FORUM



中国纺织面料流行趋势研究结合市场需求，系统化研究色彩、纤维、纱线、面料服装风格、技术以及产品开发方向，运用趋势研究的国际化、专业化和市场化研究力量，指导企业进行精准的趋势应用与产品推广。此次系列趋势论坛演讲嘉宾由中国纺织信息中心流行趋势研究专家、分品类趋势联盟研究专家组成，以 2026 春夏中国纺织面料流行趋势为引领，结合纺织服装产业链的终端需求，在产品开发、产品企划以及生产实践等多维角度进行系统化阐述，展示中国纺织面料流行趋势及分品类趋势的研究成果。

Based on market demand, Fabrics China trend research gathers international, professional, and market-oriented research resources to systematically study colors, fibers, yarns, fabrics, apparel styles, technologies, and product development directions, so as to guide enterprises to promote new products on the basis of latest trends application. The speakers of this forum are trend research experts from China Textile Information Center and sub-category trend alliances. Combining the needs of the textile and apparel industry chain, experts will elaborate on product development, product planning, and production practice based on the 2026SS Fabrics China trend research, showing related research results and category trends.

● 国内流行趋势区：

- 6.1 号馆 可持续时尚流行趋势区 (6.1-E12)
- 6.2 号馆 科技 & 功能流行趋势区 (6.2-E108)
- 7.2 号馆 牛仔流行趋势区 (7.2-E05)
- 8.1 号馆 时尚概念流行趋势区 (8.1-E16)

● 国内特色展示区：

- 6.1 号馆 可持续创新专区 (6.1-E140)
- 6.2 号馆 新技术创新空间 (6.2-E122)
- 7.1 号馆 数字时尚创新空间 (7.1-E12)

● Domestic Trend Forums:

- 6.1H Sustainable Fashion Trend Forum (6.1-E12)
- 6.2H Techno & Functions Trend Forum (6.2-E108)
- 7.2H Denim Trend Forum (7.2-E05)
- 8.1H Fashion Focus Trend Forum (8.1-E16)

● Domestic Featured Display Areas:

- 6.1H Sustainability Zone (6.1-E140)
- 6.2H Innotech Space (6.2-E122)
- 7.1H Digital Fashion Innovation Space (7.1-E12)

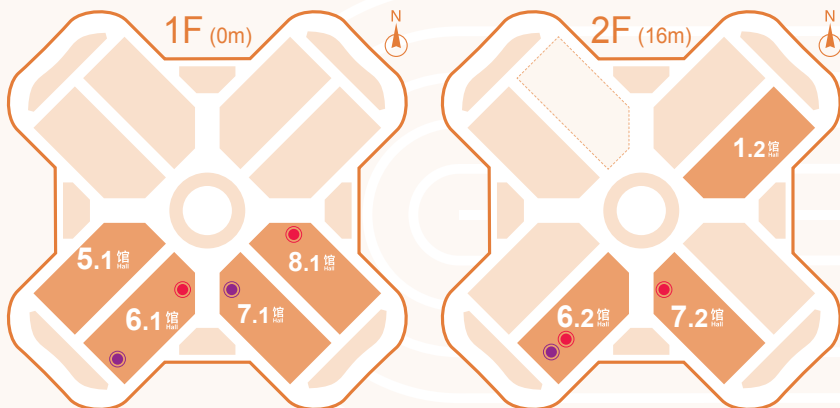





5.1-G148  
对话纺织  
Textile Dialogue

地点 Venue

5.1

## 2025.3.11

时间 Time	议程 Schedule	讲者 Speakers
13:00 - 13:40	2026 春夏中国纺织面料流行趋势 2026 Spring & Summer Fabrics China Trend	彭丽桦, 中国纺织信息中心流行趋势部 Peng Lihua, China Textile Information Center, Trend Dept
13:40 - 14:00	紧柔纺——激活传统纺织材料的焕新生命力, 解锁更多卓越性能 Sirofil - Compact Spinning Unleash Potential of Traditional Textile Materials, Unlock More Outstanding Properties	纺织新材料纱线流行趋势研究中心 孙田, 山东联润新材料科技有限公司, 江浙沪区域销售经理 Fabrics China Trend Research Center - New Fiber-based Yarn Sun Tian, Jiangsu, Zhejiang and Shanghai Regional Sales Manager, Long Run Textile Co Ltd
14:00 - 14:20	针织面料的差异化创新设计 Innovative Design for Differentiation of Knitted Fabrics	针织牛仔流行趋势研究中心 曹金燕, 恒亮纺织, 市场部经理 Fabrics China Trend Research Center - Knitted Denim Textiles Jinyan Cao, Marketing Manager, HiliteTex
14:20 - 14:40	江苏丹毛 2026 春夏趋势面料分享 2026 Spring & Summer Trend Fabric Sharing - Danmao	女装精毛纺面料流行趋势研究中心 汪晓燕, 江苏丹毛纺织股份有限公司, 面料设计师 Fabrics China Trend Research Center - Worsted Textiles for Womenswear Xiaoyan Wang, Textiles Designer, Jiangsu Danmao Textile Co Ltd
14:40 - 15:10	鲁泰集团 2026 春夏新品趋势 Luthai Group's 2026 Spring & Summer New Product Trends	色织面料流行趋势研究中心 谭文文, 鲁泰纺织股份有限公司, 设计师 Fabrics China Trend Research Center - Yarn Dyed Textiles Tan Wenwen, Designer, Luthai Textile
15:10 - 15:40	2026 春夏中国艺术染整流行趋势发布 2026 Spring & Summer Chinese Dyeing & Finishing Trend	艺术染整与现代扎染流行趋势研究中心 罗竞杰, 东华大学服装与艺术设计学院, 服装与服饰专业负责人; 东华·江苏华艺艺术染整科技创新研中心主任 Fabrics China Trend Research Center - Artistic Dyeing & Finishing and Modern Tie Dyeing Luo Jingjie, Director of Apparel & Accessories Dept, College of Fashion and Design of Donghua University; Director of Donghua · Jiangsu Huayi Artistic Dyeing & Finishing Innovation Research Center
15:40 - 16:10	2026 春夏图案趋势分析 2026 Spring & Summer Pattern Trend Analysis	洪溶, 中国纺织信息中心, 时尚智能部运营经理 Hong Ron, Operations Manager of Fashion Intelligence Department, China Textile Information Center

## 2025.3.12

时间 Time	议程 Schedule	讲者 Speakers
10:30 - 11:10	2026 春夏东方美学色彩趋势应用 Application of Eastern Aesthetic Color Trends in Spring/Summer 2026	赖正亮, 上海元彩科技有限公司, 色彩趋势应用专家 Zhengliang Lai, Color Trend Application Expert, Coloro
11:10 - 11:40	以纱为笔, 绘就生态永续蓝图 Using Yarn as a Brush to Paint a Blueprint for Ecological Sustainability	差别化功能性色纺纱流行趋势研究中心 张淑云, 德州华源生态科技有限公司, 市场部副部长 Fabrics China Trend Research Center - Functional Colored Spun Yarn Zhang Shuyun, Deputy Director of the Marketing Department, Dezhou Huayuan Eco-Technology Co Ltd
11:40 - 12:00	关于牛仔的趋势信息和可持续发展 The Fashion Trend and Sustainability Develop Relate Denim	杨闯, 广东前进牛仔布有限公司, 产品市场经理 Eric Yang, Marketing Manager, Advance Denim Co Ltd
12:00 - 12:30	2026 SS 黑牡丹牛仔面料趋势及产品分享 2026 SS Denim Fabric Trends and Products Sharing - Black Peony	郭伟, 黑牡丹纺织有限公司, 产品部部长 WILL, Product Director, Black Peony Textile Co Ltd
12:30 - 13:00	焕然一“芯”绿动未“莱” Lycell by Sateri Facilitates the Green and Sustainable Development of the Industry	刘国松, 赛得利集团, 下游市场拓展经理 Guosong Liu, BD Manager, Sateri Group

\* 提供普通话 ↔ 英语同声传译

\* Mandarin Chinese ↔ English Simultaneous Interpretation will be provided

# 重点活动 – 可持续发展议题

## FEATURED EVENTS – ECONOGY TALKS

地点 Venue



5.1-K48  
可持续发展论坛  
Econogy Talks

5.1

### 全球纺织行业的循环经济——机遇与挑战 Circularity in the Global Textile Industry – Opportunities and Challenges

论坛  
FORUM



随着全球可持续发展法规的不断演变，纺织行业正面临复杂的挑战，同时也迎来了令人振奋的新机遇。欢迎加入我们的专家小组会议，共同探讨以下议题：

1. **各地区法规动态**——探讨新法规及即将出台的政策如何重塑全球供应链，为纺织行业带来转型挑战与发展契机。
2. **主要挑战**——从原材料采购到废弃物管理，从合规要求到运营调整，全面剖析纺织行业在循环经济中的关键难题。
3. **亚洲生产商的机遇**——深入发掘亚洲生产商如何在新兴市场中制定增长策略，发挥竞争优势，推动区域可持续发展。

切勿错过这场深入且专业的讨论！我们将共同探索政策变化、创新解决方案及合作模式如何推动全球纺织行业迈向更可持续、更具盈利能力的未来！

As sustainability regulations continue to evolve worldwide, the textile industry faces both complex hurdles and exciting new possibilities. Join our expert panel to explore:

1. **Legislation Across Regions** - How new and upcoming laws will reshape global supply chains.
2. **Key Challenges** - From material sourcing to waste management and compliance.
3. **Opportunities for Asian Producers** - Identifying growth strategies and competitive advantages in emerging markets.

Don't miss this in-depth discussion on how shifting policies, innovative solutions, and collaborative approaches can foster a more sustainable and profitable future for the global textile industry.

### 2025.3.12

时间 Time	议程 Schedule	讲者 Speakers
14:55 - 16:25	全球纺织行业的循环经济——机遇与挑战 Circularity in the Global Textile Industry - Opportunities and Challenges	主持人： Karl Borgschulze, 咨询服务国际董事总经理 嘉宾： 赵芳美, 北京爱科赛尔认证中心有限公司, 可持续发展产品事业部经理及华东分中心负责人 Eva McGeorge, 全球市场高级总监, 兰精集团 Morgane Parizot, Redress 教育总监 黄伟基 Moderator: Karl Borgschulze, Managing Director, Consulting Service International Speakers: Fangmei Zhao, Ecoproduct BU Product Manager and East China Office Manager, Beijing ECOCERT Certification Centre Co Ltd Eva McGeorge, Senior Global Marketing Director, Lenzing Group Morgane Parizot, Strategic Education Director, Redress Justin Huang

\* 提供普通话 ↔ 英语同声传译

\* Mandarin Chinese ↔ English Simultaneous Interpretation will be provided

# 重点活动 – 可持续发展议题

## FEATURED EVENTS – ECONOGY TALKS

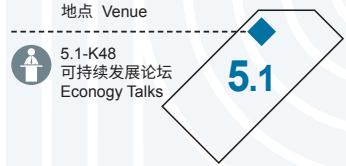

### Material X – 可持续未来材料研讨

#### Material X: NextGen Sustainable Solutions

论坛  
FORUM



2025.3.11		
时间 Time	议程 Schedule	讲者 Speakers
13:00 - 13:05	开场介绍 Opening Introduction	
13:05 - 13:10	领导致辞 Leadership Speech	
13:10 - 13:40	可持续未来材料实验室：时尚的科学幻想 Sustainable Future Materials Lab: The Science of Fashion Fantasy	胡柯华, 中国纺联社会责任办公室副主任 Kehua Hu, Deputy Director, Social Responsibility Office, China National Textile and Apparel Council
13:40 - 14:10	全球纺织新材料产业发展趋势 Global Development Trends in New Textile Materials	关晓宇, 北京服装学院材料设计与工程学院教授 Xiaoyu Guan, Professor, School of Material Design and Engineering, Beijing Institute of Fashion Technology
14:10 - 14:30	cycora® – 助力国际供应链绿色转型升级的下一代新材料 cycora® - Next Generation New Materials Driving the Green Transformation and Upgrading of the International Supply Chain	Matthew Iezzi, 美国 Ambercycle 新材料公司生产总监 Matthew Lezzi, Head of Production, Ambercycle Inc (USA)
14:30 - 14:50	技术革新赋能菌草纤维——白鹭开启深绿发展新时代 Technological Innovation Empowers Juncao Fiber, Bailu Ushers in a New Era of Dark Green Development	关德众, 新乡化纤股份有限公司菌草事业部总经理 Dezhong Guan, General Manager, Juncao Division, Xinxiang Chemical Fibre Co Ltd
14:50 - 15:10	兰精集团的可持续材料实践与产业链协同 Lenzing Group's Sustainable Material Practices and Industry Chain Collaboration	刘爽, 兰精集团北亚区可持续发展经理 Shuang Liu, North Asia Sustainability Manager, Lenzing
15:10 - 15:30	品牌视角下的可持续材料应用与实践 Sustainable Material Applications from a Brand Perspective	刘维, 李宁公司可持续发展总监 Wei Liu, Sustainability Director, Li-Ning Company

\* 提供普通话 ↔ 英语同声传译  
\* Mandarin Chinese ↔ English Simultaneous Interpretation will be provided

# 重点活动 – 可持续发展议题

## FEATURED EVENTS – ECONOGY TALKS

6.1-E141  
热点交流  
Talking Point

6.1

地点 Venue

### 纺织服装行业产品碳足迹发布 Release of Product Carbon Footprint in the Textile and Apparel Industry

论坛  
FORUM



2025.3.12

时间 Time	议程 Schedule	讲者 Speakers
10:30 - 10:35	领导致辞 Opening Speech	
10:35 - 10:50	纺织产品碳足迹核算标准与关键技术 Carbon Footprint Calculation Standards and Key Technologies for Textile Products	王来力, 浙江理工大学教授 Laili Wang, Professor, Zhejiang Sci-Tech University
10:50 - 11:05	时尚行业产品碳足迹工作进展 Progress of Carbon Footprint Work in the Fashion Industry	孔衍, 中国纺织信息中心可持续发展合作部助理研究员 Yan Kong, Assistant Researcher on Sustainable Development, China Textile Information Center
11:05 - 11:20	绿色消费引领下的时尚品牌“碳索” Carbon Quest: Fashion Brands Pioneering Green Consumption	郭肇一, 浙江森马服饰股份有限公司经营企划专家 Zhaoyi Guo, Business Planning Expert, Zhejiang Semir Garment Co Ltd
11:20 - 11:35	牛仔先锋的低碳变革之路 The Low-Carbon Transformation Journey of Denim Pioneer	黎瑞珊, 广东前进牛仔布有限公司总经理助理 Ruishan Li, Assistant General Manager, Guangdong Advance Denim Co Ltd
11:35 - 11:50	解锁必维认证产品碳足迹认证核查“密码” Unlocking the "Code" for BV Certification's Product Carbon Footprint Certification Audit	黄敏, 必维中国区 ESG 和可持续发展负责人 Min Huang, Head of ESG and Sustainable Development, Bureau Veritas China
11:50 - 12:00	纺织行业产品碳足迹管理体系团体标准介绍 Introduction to the Group Standard of Carbon Footprint Management System for Textile Products	胡雪睿, 中国纺联社会责任办公室助理研究员 Xuerui Hu, Assistant Researcher, Office for Social Responsibility, China National Textile and Apparel Council

\* 提供普通话 ↔ 英语同声传译

\* Mandarin Chinese ↔ English Simultaneous Interpretation will be provided

## 可持续发展巡馆导览 Econogy Tour

在一小时的 Econogy Tour 巡馆导览中将由一名独立顾问带大家拜访拥有环保标签及认证的参展企业。参与导览的观众可以与参展商及专家在绿色纺织创新的议题上进行深入交流。

日期: 2025 年 3 月 11 日  
时间: 14:00 - 15:00  
集合地点: 5.1-K48 可持续发展论坛场地外

The one-hour Econogy Tour to sustainability-focused exhibitors is guided by an independent consultant, enabling an in depth exchange on the latest green textile innovations.

Date: 11 March 2025  
Time: 14:00 - 15:00  
Meeting point: Outside Econogy Talks (5.1-K48)

\* 无需登记即可参加导览。

\* Registration is not required to join the tour.

## 重点活动 – 市场信息及营销策略

### FEATURED EVENTS – MARKET INFORMATION & BUSINESS STRATEGIES

**面料创新的未来视野：创新、可持续与文化交融**  
**——中国流行面料 CLUB 面料创新探秘**  
**Future Perspectives on Fabric Innovation: Innovation, Sustainability, and Cultural Integration - Exploring Fabric Innovation with Fabrics China CLUB**

论坛  
FORUM



在科技飞速发展的时代，面料不仅仅是服装的基础，更是时尚、功能与可持续发展的重要载体，特别是全球化背景下，人们更希望通过服装和面料传递文化认同和情感联系。

面料的未来将如何与科技、设计和可持续发展相结合，色彩如何赋能面料创新？

我们将围绕东方国色、创新材料、人文自然以及智慧科技等维度，分享行业内的成功案例和创新应用，共同探讨这个充满活力与机遇的话题。

In an era of rapid technological advancement, fabric is not just the foundation of clothing but also a crucial carrier of fashion, functionality, and sustainable development. Especially in the context of globalization, people increasingly hope to convey cultural identity and emotional connections through clothing and fabrics.

In the future, how will fabrics integrate with technology, design, and sustainability? And how can color empower fabric innovation?

We will share successful industry cases and innovative applications, focusing on dimensions such as Oriental aesthetics, innovative materials, human-nature harmony, and smart technology, to explore this vibrant and opportunity-rich topic together.



6.1-E141  
 热点交流  
 Talking Point

地点 Venue

6.1

2025.3.11

时间 Time	议程 Schedule	讲者 Speaker
14:00 - 15:00	东方国色，生生不息《中国传统色应用色卡》发布 The Release of "Classical Color Collections of China"	张玮, Coloro 色彩应用研究院院长, 中国纺织信息中心副主任 Wei Zhang, Director, Coloro Institute; VP CTIC 黄荣华, 李子柒“春晚战袍”染制者、植物染技艺非遗传承人 Ronghua Huang, Inheritor of The Intangible Cultural Heritage of Plant Dyeing Craft
15:00 - 15:20	The Thinner The Better——优可丝纤柔助力效率与品质双升级 The Thinner The Better - Ecocosy Improve the Efficiency and Quality	颜荟, 赛得利市场高级经理 Effy Yan, Marketing Senior Manager, Sateri
15:20 - 15:40	以功能与绿色纤维赋能品牌可持续发展 Empowering Brand Sustainable Development with Functional and Green Fibers	阙丹, 福建永荣锦江股份有限公司, 品牌与商务部总监 Dan Que, Director, Brand and Commercial Department, Fujian Yongrong Jinjiang Co Ltd
15:40 - 16:00	丝柔纺: 天然纱线实现可持续功能性解决方案 Silrospun: Natural Yarns for Sustainable Functional Solutions	栾熙忠, 卡莱多(上海)纺织科技有限公司, 董事 Luke, Director, Karado (Shanghai) Textile & Garment Co Ltd
16:00 - 16:20	「在风中」系列——AI 仿印经绸系列面料全新发布 The "In the Wind" Series - AI Imitation Printed Silk Series Fabric New Release	蒋璐, 浙江凯喜雅智纺科技有限公司, 总经理 Lulu, General Manager, Zhejiang Cathaya Intelligent Textile Technology Co Ltd
16:20 - 16:40	解码“真”需求, 织就未来——高端裤装面料产品创新之路 Decoding The "True" Demand, Weaving the Future - The Path of Innovation for High-end Trousers Fabric	王堃, 广州帛璟纺织品有限公司, 总经理 Kun Wang, General Manager, Guangzhou Bojing Textile Co Ltd
16:40 - 17:00	重构与新生: 刺绣行业从传统制造到智能创造的跃升 Reconstruction and New Life: The Leap from Traditional Manufacturing to Intelligent Creation in the Embroidery Industry	王明亮, 绍兴明晗绣品有限公司, 总经理 Mingliang Wang, General Manager, Shaoxing Minghee Embroidery Co Ltd
17:00 - 17:20	科技、文化与可持续融入牛仔面料的创新变革 Innovation and Transformation of Technology, Culture, and Sustainable Integration into Denim	涂强, 广州市谊兴纺织有限公司, 品牌营销总监 Qiang Tu, Brand Marketing Director, Guangzhou Winwin Textile Co Ltd

\* 提供普通话 ↔ 英语同声传译

\* Mandarin Chinese ↔ English Simultaneous Interpretation will be provided

# 重点活动 – 市场信息及营销策略

## FEATURED EVENTS – MARKET INFORMATION & BUSINESS STRATEGIES

6.1-E141  
热点交流  
Talking Point

6.1

地点 Venue

### 时尚行业数字化转型发展趋势与技术应对 Digital Transformation Development Trend and Technology Response in the Fashion Industry

论坛  
FORUM



本次活动从精准洞察需求、增强创新能力、提升运营效率和优化业务流程多个维度，进行行业数字化转型发展趋势和战略应对介绍。围绕数字技术应用实践，探讨行业未来发展方向，旨在提高纺织服装企业数字化转型能力。

Introduce the development trends and technological responses of the industry's digital transformation from multiple dimensions such as accurately gaining insight into demands, strengthening innovation capabilities, improving operational efficiency and optimizing business processes. Focus on the application and practice of digital technologies and explore the future development directions of the industry, aiming to enhance the digital transformation capabilities of textile and apparel enterprises.

2025.3.11		
时间 Time	议程 Schedule	讲者 Speakers
10:30 - 10:55	从设计到生产的数字色彩管理——赋予色彩的技术力量 Digital Color Management from Design to Production - Empowering Technology for Color	Detlev Pross, 上海元彩科技有限公司首席策略官 Detlev Pross, Chief Strategy Officer, Coloro
10:55 - 11:20	数据 & AI 助力面料色彩：天猫 TMIC 服饰新趋势 Create a "Product-Commodity Double Cycle" - Cast the Product Core with Ingenuity, and Achieve the Optimal Value Transformation of Service Enterprises	皓米, TMIC 服饰运动负责人 Emmy, Manager, TMIC Apparel & Sports
11:20 - 11:45	穿搭新风尚：服饰赛道下的未来消费趋势洞察 New Fashion Trends in Dressing: Insights into Future Consumption Trends in the Fashion Industry	易凡, 魔镜洞察高级分析师 Fan Yi, Senior Analyst, Moojing Market Intelligence
11:45 - 12:05	打造“产品-商品双循环”-以匠心铸就产品内核, 实现服企商品最优价值转化 Create a "Product-Commodity Double Cycle" - Cast the Product Core with Ingenuity, and Achieve the Optimal Value Transformation of Service Enterprises	冯恺, 赛趋科软件(上海)有限公司资深业务顾问 William Feng, Senior Business Consultant, Centric Software
12:05 - 12:30	AI 视觉检测在纺织行业的应用实践 Application Practice of AI Vision Inspection in the Textile Industry	朱如江, 南通巨联数字科技有限公司副总经理 Rujiang Zhu, Deputy General Manager, Nantong Julian Digital Technology Co Ltd

\* 提供普通话 ↔ 英语同声传译

\* Mandarin Chinese ↔ English Simultaneous Interpretation will be provided



# 重点活动 – 技术

## FEATURED EVENTS – TECHNOLOGY AND SOLUTIONS

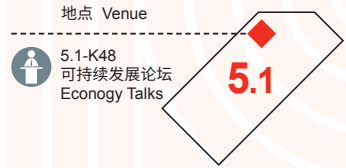

### 创新铸就可持续未来 ——突破挑战、协同合作、深化影响

### Shaping the Future of Sustainability Through Innovation - Overcoming Obstacles, Fostering Cooperation, and Driving Impact

**论坛**  
**FORUM**



欢迎加入我们的专题小组会议，与行业专家共同参与一场富有深度的讨论，共同探索如何通过创新解决方案推动可持续发展，以迈向新高度。本次讨论将重点围绕以下议题展开：

1. **识别并克服障碍**——深入探讨应对当前最严峻的可持续发展挑战的有效策略。
2. **合作与伙伴关系**——汇聚集体智慧，构建具有韧性且高影响力的解决方案。
3. **提升可持续实践**——通过扩大创新应用，实现更高的环境与社会效益，同时确保企业的长期发展和增长。

Join our expert panel for a dynamic conversation on how to propel sustainability initiatives to the next level with a focus on innovative solutions. We will explore:

1. **Identifying and Overcoming Barriers** - Strategies to tackle the most pressing sustainability challenges.
2. **Collaboration and Partnerships** - Harnessing collective expertise to create resilient, high-impact solutions.
3. **Elevating Sustainable Practices** - Scaling innovation for greater environmental and social returns while ensuring long-term business growth.

2025.3.12		
时间 Time	议程 Schedule	讲者 Speakers
11:15 - 12:45	创新铸就可持续未来——突破挑战、协同合作、深化影响 Shaping the Future of Sustainability Through Innovation - Overcoming Obstacles, Fostering Cooperation, and Driving Impact	主持人： Karl Borgschulze, 咨询服务国际董事总经理 嘉宾： 马磊, 伊士曼（中国）投资管理有限公司, 亚太区集团可持续发展经理 Denier Qi, 达利（中国）有限公司, Advance Textiles 市场总监 陈念群, 香港纺织及成衣研发中心总监（业务拓展） 陈德宏, TextileGenesis（简称 TG 公司, 为 Lectra 旗下企业），大中华区总监 Moderator: Karl Borgschulze, Managing Director, Consulting Service International Speakers: Lei Ma, AP Sustainability Manager, Eastman Denier Qi, Marketing Director of Advance Textiles, High Fashion (China) Company Limited Katherine Chan, Director of Business Development, HKRITA Simon Chen, Greater China Regional Lead, TextileGenesis, a Lectra Company

\* 提供普通话 ↔ 英语同声传译  
 \* Mandarin Chinese ↔ English Simultaneous Interpretation will be provided

## 重点活动 – 技术

### FEATURED EVENTS – TECHNOLOGY AND SOLUTIONS

**Intertextile FORUM 纺织论坛**  
**数智融合创新，打开国际合作新局面**  
**Digital and Intelligent Integration and**  
**Innovation: Opening up a New Chapter for**  
**International Cooperation**

论坛  
FORUM



在全球经济一体化的大潮之中，纺织产业链接资源，开拓海外市场面临着需要以更加精准、多元的服务稳订单、拓市场。为了开启纺织产业高质量发展的新未来，开辟国际合作新局面，除了要以开放的姿态、全球的视野接轨全球，数智融合在支撑产业精准创新以及高质量发展的过程中，同样是不可或缺的动力和破局点。因此要继续深入实施纺织现代化产业体系行动纲要（2022-2035年）7大行动，以全球视野的中国主张、中国智慧、中国方案，帮助企业品牌和产业向“新”提“质”。营造有利于产业发展的国际合作环境，推动行业融入全球，实现与全球纺织产业合作共赢的新局面。

In the tide of global economic integration, the textile industry faces the challenge of stabilizing orders and expanding markets through more precise and diversified services when connecting resources and exploring overseas markets. To open up a new future for the high-quality development of the textile industry and create a new landscape for international cooperation, in addition to aligning with the global market with an open approach and a global perspective, the digital and intelligent integration is also an indispensable driving force and breakthrough point at the core of supporting the industry's precise innovation and high-quality development. Therefore, it is necessary to continue to thoroughly implement the seven major actions of the Action Plan for Building a Modern Textile Industry System (2022-2035), leveraging China's global vision, Chinese wisdom, and Chinese solutions to help elevate the quality and innovation of enterprise brands and the industry as a whole. To creating a favorable international environment for industrial development, driving the industry's integration into the global market, and realizing a new chapter in the global textile industry through integration, cooperation, and win-win results.



6.1

地点 Venue

## 2025.3.12

时间 Time	议程 Schedule	讲者 Speakers
13:30 - 13:35	主持嘉宾开场 Opening Remarks by the Host	郑嵘, 东华大学教授 Rong Zheng, Professor, Donghua University
13:35 - 14:05	领导致辞 Opening Address	
14:05 - 14:20	可持续发展与 ESG: 高端时装品牌集团的实践与启示 Sustainability & ESG at Multi-brand Fashion Group	Dominique Simard, 歌力思集团首席可持续时尚官 Dominique Simard, Chief Sustainable Fashion Officer, Ellassay Group
14:20 - 14:35	唤醒设计的初心与热爱 Put Passion Back in Design	Simon Collins, 帕森斯设计学院前院长、清华大学设计顾问、教授 Simon Collins, Former Dean at Parsons School of Fashion, Design Consultant and professor at Tsinghua University
14:35 - 14:50	欧美新法规环境下的供应链追溯 Supply Chain Traceability in the New Regulatory Landscape	陈德宏, TextileGenesis 大中华地区总监 Simon Chen, Greater China Regional Lead, TextileGenesis, a Lectra company
14:50 - 15:25	主题对话一: 寻求破局, 数智融合创新生态 Thematic Dialogue 1: Breaking the Impasse - The Ecosystem of Digital and Intelligent Integration and Innovation	王耀民, 上海三问家居科技股份有限公司董事长 吴铭焱, 迪尚集团供应链管理中心总经理 翁文瑾, 英特密澳大利亚有限公司 CELYS 销售总监 刘丽娜, 3M 中国有限公司消费品事业部、纺织及服装材料部亚太区业务总经理 包庆, 恒纶纺织(中国 越南)有限公司开发部总监 林蔚清, 数智世界集团供应链公司总经理 Yaomin Wang, Chairman, SUNWIN Mingyan Wu, General Manager of Supply Chain Management Center, Dishang Group Helen Weng, Sales Director of CELYS, INTIMITI Australia Pty Ltd Jackie Liu, APAC Business Leader of Consumer Business Group and Apparel & Textile, 3M China Limited Qing Bao, Director of Development Department, Henglun Textile (China Vietnam) Co Ltd Leo Lin, General Manager, Shanghai Digital Intelligent World Industrial Technology Group Co Ltd
15:25 - 16:00	主题对话二: 开启未来, 国际合作高质量发展新格局 Thematic Dialogue 2: Opening the Future - A New Pattern for High-Quality Development in International Cooperation	王笃森, 歌力思集团事业合伙人、集团董事兼创意总监 盛宇, GOELIA 歌莉娅海外经营担当 黄海滨, Liberty 亚洲区销售运营总监 朱蓉萍, 黑牡丹纺织有限公司常务副总经理 王绍球, 宝亚(香港)国际有限公司销售经理 陈德宏, TextileGenesis 大中华地区总监 Dusen Wang, Business Partner and Creative Director, ELLASSAY Emily, Director of Overseas Business, GOELIA Haibin Huang, Director of Sales Operations in Asia Region, Liberty Rongping Zhu, Executive Deputy General Manager, Black Peony textile Co Ltd Alfred Wong, Sales Manager, Poly Asia (HK) International Limited Simon Chen, Greater China Regional Lead, TextileGenesis, a Lectra company

\* 提供普通话 ↔ 英语同声传译

\* Mandarin Chinese ↔ English Simultaneous Interpretation will be provided

最终大会日程及到场嘉宾以现场为准, 最终解释权归中国国际贸易促进委员会纺织行业分会。

The final forum agenda and guests are subject to change. The final interpretation right belongs to the Sub-Council of Textile Industry of China Council for the Promotion of International Trade (CCPIT-TEX)

## 重点活动 – 技术

## FEATURED EVENTS – TECHNOLOGY AND SOLUTIONS

2025 国际纺织产业数字化应用趋势论坛  
2025 International Textile Industry Digital  
Application Trend Forum

论坛  
FORUM



“国际纺织产业数字化应用趋势论坛”议题涵盖设计研发数字化、生产过程数字化、供应链管理数字化等。通过汇聚国际领先的数字化解决方案提供商、服务商企业代表，展开创新性的数字化产品工具、解决方案及应用案例分享，全面展示当下国际纺织服装行业的前沿产品技术及应用趋势。与此同时，促进国内外纺织产业的技术交流和商贸对接。

The "International Textile Industry Digital Application Trend Forum" covers topics such as digital design and research and development, digital production processes, and digital supply chain management. By gathering representatives of leading international digital solution providers and service providers, innovative digital product tools, solutions, and application cases are shared to comprehensively showcase the cutting-edge product technology and application trends of the current international textile and clothing industry. At the same time, it promotes technical exchanges and business connections between domestic and foreign textile industries.



5.1-G148  
对话纺织  
Textile Dialogue

地点 Venue

5.1

## 2025.3.12

时间 Time	议程 Schedule	讲者 Speakers
14:05 - 14:15	开幕辞 Opening Speech	余诗慧, 法兰克福展览 (香港) 有限公司总经理 Wilmet Shea, General Manager, Messe Frankfurt (HK) Ltd
14:15 - 14:35	纺织数字化现状和趋势市场分析 Frontiers of Digital Textile and Apparel Technologies and the AI Empowerment Paradigm	钟跃崎, 东华大学纺织学院教授 Yueqi Zhong, Professor, School of Textiles, Donghua University
14:35 - 14:55	为什么我的颜色不对? 将物理颜色转化为数字工作流程 Why are My Colors Wrong? - Finally Transforming Physical Color into Digital Workflows	孙伊, 上海元彩科技有限公司, 数字色彩专家 Yi Sun, Digital Color Expert, Coloro
14:55 - 15:15	启发式机器学习算法在纺织 APS 上的应用 Application of Heuristic Machine Learning Algorithm in Textile APS	孙亮, 飞弗信息科技 (上海) 有限公司总经理 Liang Sun, General Manager, Feifu Information Technology (Shanghai) Co Ltd
15:15 - 15:35	创新科技驱动下的纺织服装业变革 The Transformation of the Textile and Clothing Industry Driven by Innovative Technology	林广川, 广东匡敦科技有限公司商务总监 Guangchuan Lin, Business Director, Guangdong Quaternion Technology Ltd
15:35 - 15:55	服装企业如何实现供应链数字化转型? How can Clothing Companies Achieve Digital Transformation of Their Supply Chain?	丁腾飞, 苏州飞榴科技有限公司销售 VP Tengfei Ding, Sales VP, Feiliu (Shanghai) Information Technology Co Ltd
15:55 - 16:25	圆桌会议: 人工智能在纺织面料研发创新中的应用与发展趋势 Panel Discussion: Application and Development Trends of Artificial Intelligence in Textile Fabric Research and Innovation	主持人: 钟跃崎, 东华大学纺织学院教授 嘉宾: 孙伊, 上海元彩科技有限公司数字色彩专家 孙亮, 飞弗信息科技 (上海) 有限公司总经理 林广川, 广东匡敦科技有限公司商务总监 丁腾飞, 苏州飞榴科技有限公司销售 VP Moderator: Yueqi Zhong, Professor, School of Textiles, Donghua University Speakers: Yi Sun, Digital Color Expert, Coloro Liang Sun, General Manager, Feifu Information Technology (Shanghai) Co Ltd Guangchuan Lin, Business Director, Guangdong Quaternion Technology Ltd Tengfei Ding, Sales VP, Feiliu (Shanghai) Information Technology Co Ltd

\* 提供普通话 ↔ 英语同声传译

\* Mandarin Chinese ↔ English Simultaneous Interpretation will be provided

# 活动总览 – 流行趋势

## EVENT OVERVIEW – DESIGN AND TRENDS

**2025.3.11**

时间 Time 地点 Venue	主题 Topic	讲者 Speakers	语言 Language
10:15 - 11:05 5.1-G148	<b>研讨会 Seminar</b> 中国传统色彩的色彩内涵和应用研究 Research on the Colour Connotation and Application of Traditional Chinese Colours	王刘莹, 上海元彩科技有限公司, CMF 应用管理色彩专家 Liuying Wang, Coloro Co Ltd, CMF Application Management Color Expert	普通话 * Mandarin*
11:10 - 12:00 5.1-G148	<b>研讨会 Seminar</b> Intertextile 2026 春夏色彩、面料及流行趋势 Intertextile Trends: Colours, Fabrics and Fashion Trends Spring-Summer 2026	Omella Bignami, Elementi Moda 主理人兼艺术总监 Omella Bignami, Owner and Art Director, ELEMENTI MODA - Milan (Italy)	英语 * English*
12:05 - 12:55 5.1-G148	<b>研讨会 Seminar</b> 心灵: 混合平衡元素, 大胆打造出冲击心灵的 2026 春夏色彩 Mind: Blending the Balanced and Bold for a Mind-Bending Vision for Spring/Summer 2026	Laurie Pressman, 潘通色彩研究所副总裁 Laurie Pressman, Vice President, Pantone Color Institute	英语 * English*
13:00 - 13:40 5.1-G148	<b>论坛 Forum</b> 2026 春夏中国纺织面料流行趋势 2026 Spring & Summer Fabrics China Trend	彭丽桦, 中国纺织信息中心流行趋势部 Peng Lihua, China Textile Information Center, Trend Dept	普通话 * Mandarin*
13:40 - 14:00 5.1-G148	<b>论坛 Forum</b> 紧柔纺——激活传统纺织材料的焕新生命力, 解锁更多卓越性能 Sirofil - Compact Spinning Unleash Potential of Traditional Textile Materials, Unlock more Outstanding Properties	纺织新材料纱线流行趋势研究中心 孙田, 山东联润新材料科技有限公司, 江浙沪区域销售经理 Fabrics China Trend Research Center - New Fiber-based Yarn Sun Tian, Jiangsu, Zhejiang and Shanghai Regional Sales Manager, Long Run Textile Co Ltd	普通话 * Mandarin*
14:00 - 14:20 5.1-G148	<b>论坛 Forum</b> 针织面料的差异化创新设计 Innovative Design for Differentiation of Knitted Fabrics	针织牛仔流行趋势研究中心 曹金燕, 恒亮纺织, 市场部经理 Fabrics China Trend Research Center - Knitted Denim Textiles Jinyan Cao, Marketing Manager, Hilitetex	普通话 * Mandarin*
14:20 - 14:40 5.1-G148	<b>论坛 Forum</b> 江苏丹毛 2026 春夏趋势面料分享 2026 Spring & Summer Trend Fabric Sharing - Danmao	女装精毛纺面料流行趋势研究中心 汪晓燕, 江苏丹毛纺织股份有限公司, 面料设计师 Fabrics China Trend Research Center - Worsted Textiles for Womenswear Xiaoyan Wang, Textiles Designer, Jiangsu Danmao Textile Co Ltd	普通话 * Mandarin*
14:40 - 15:10 5.1-G148	<b>论坛 Forum</b> 鲁泰集团 2026 春夏新品趋势 Luthai Group's 2026 Spring & Summer New Product Trends	色织面料流行趋势研究中心 谭文文, 鲁泰纺织股份有限公司, 设计师 Fabrics China Trend Research Center - Yarn dyed Textiles Tan Wenwen, Designer, Luthai textile	普通话 * Mandarin*
15:10 - 15:40 5.1-G148	<b>论坛 Forum</b> 2026 春夏中国艺术染整流行趋势发布 2026 Spring & Summer Chinese Dyeing & Finishing Trend	艺术染整与现代扎染流行趋势研究中心 罗竞杰, 东华大学服装与艺术设计学院, 服装与服饰专业负责人; 东华·江苏华艺艺术染整科技创新中心主任 Fabrics China Trend Research Center - Artistic Dyeing & Finishing and Modern Tie Dyeing Luo Jingjie, Director of Apparel & Accessories Dept, College of Fashion and Design of Donghua University; Director of Donghua · Jiangsu Huayi Artistic Dyeing & Finishing Innovation Research Center	普通话 * Mandarin*



5.1-G148  
对话纺织  
Textile Dialogue

地点 Venue

5.1

15:40 - 16:10 **论坛 Forum**  
5.1-G148 2026 春夏图案趋势分析  
2026 Spring & Summer Pattern Trend Analysis  
洪溶, 中国纺织信息中心, 时尚智能部运营经理  
Hong Ron, Operations Manager of Fashion Intelligence Department, China Textile Information Center  
普通话 \*  
Mandarin\*

16:15 - 17:05 **研讨会 Seminar**  
5.1-G148 WGSN 2026 春夏女装面料趋势预测  
Women's Textiles Forecast S/S 26  
门淑萍, WGSN 趋势总监  
Maggie Men, Trends Director, WGSN  
普通话 \*  
Mandarin\*

## 2025.3.12

时间 Time 地点 Venue	主题 Topic	讲者 Speakers	语言 Language
10:30 - 11:10 5.1-G148	<b>论坛 Forum</b> 2026 春夏东方美学色彩趋势应用 Application of Eastern Aesthetic Color Trends in Spring/Summer 2026	赖正亮, 上海元彩科技有限公司, 色彩趋势应用专家 Zhengliang Lai, Color Trend Application Expert, Coloro	普通话 * Mandarin*
11:10 - 11:40 5.1-G148	<b>论坛 Forum</b> 以纱为笔, 绘就生态永续蓝图 Using Yarn as a Brush to Paint a Blueprint for Ecological Sustainability	差别化功能性色纺纱流行趋势研究中心 张淑云, 德州华源生态科技有限公司, 市场部副部长 Fabrics China Trend Research Center - Functional Colored Spun Yarn Zhang Shuyun, Deputy Director of the Marketing Department, Dezhou Huayuan Eco-Technology Co Ltd	普通话 * Mandarin*
11:40 - 12:00 5.1-G148	<b>论坛 Forum</b> 关于牛仔的趋势信息和可持续发展 The Fashion Trend and Sustainability Develop Relate Denim	杨闯, 广东前进牛仔布有限公司, 产品市场经理 Eric Yang, Marketing Manager, Advance Denim Co Ltd	普通话 * Mandarin*
12:00 - 12:30 5.1-G148	<b>论坛 Forum</b> 2026 SS 黑牡丹牛仔面料趋势及产品分享 2026 SS Denim Fabric Trends and Products Sharing - Black Peony	郭伟, 黑牡丹纺织有限公司, 产品部部长 WILL, Product Director, Black Peony Textile Co Ltd	普通话 * Mandarin*
12:30 - 13:00 5.1-G148	<b>论坛 Forum</b> 焕然一“芯” 绿动未“莱” Lyocell by Sateri Facilitates the Green and Sustainable Development of the Industry	刘国松, 赛得利集团, 下游市场拓展经理 Guosong Liu, BD Manager, Sateri Group	普通话 * Mandarin*
13:10 - 14:00 5.1-G148	<b>研讨会 Seminar</b> 26 春夏女装趋势讲解 2026 SS Women's Fashion Trend Forecast	Benedicte Peaudecerf, PeclersParis, 风格与趋势研究设计师 Benedicte Peaudecerf, Style Designer and Trend Forecaster, PeclersParis	英语 * English*

\* 提供普通话 ↔ 英语同声传译

\* Mandarin Chinese ↔ English Simultaneous Interpretation will be provided

# 活动总览 – 可持续发展议题

## EVENT OVERVIEW – ECONOGY TALKS

### 2025.3.11

时间 Time 地点 Venue	主题 Topic	讲者 Speakers	语言 Language
10:20 - 10:50 5.1-K48	<b>研讨会 Seminar</b> 认识 GOTS - (由有机纤维制成的) 可持续和道德纺织品之源 Meet GOTS - Your Source for Sustainable and Ethical Textiles Made with Organic Fibres	时怡, 全球有机纺织品标准 (GOTS) 亚太区代表人 Felicia Shi, Representative in APAC, Global Organic Textile Standard (GOTS)	普通话 * Mandarin*
11:00 - 11:30 5.1-K48	<b>研讨会 Seminar</b> OEKO-TEX® 新规解读与 TESTEX 创 新产品引领纺织业可持续未来 Interpretation of OEKO-TEX® New Regulations and TESTEX New Products Leading the Sustainable Future of the Textile Industry	施剑, TESTEX 上海中国区运营总监 James Shi, Head of Operations China, TESTEX (Shanghai) Textile Testing Co Ltd	普通话 * Mandarin*
11:40 - 12:10 5.1-K48	<b>研讨会 Seminar</b> 材料很重要 Materials Matter	孙春红, 杭州爱达福乐检测技术有限公司认证部经理 Mary Sun, Certification Manager, IDFL	普通话 * Mandarin*
12:20 - 12:50 5.1-K48	<b>研讨会 Seminar</b> OEKO-TEX® 2025 新规解析及 PFAS 合规管控指南 Analysis of OEKO-TEX® 2025 New Regulations and Compliance Management Guidelines for PFAS	林凤玲, 海恩斯坦检测认证 (上海) 有限公司, 技术主管 Lisa Lin, Technical Supervisor, Hohenstein Laboratories (Shanghai) Co Ltd	普通话 * Mandarin*
13:00 - 15:30 5.1-K48	<b>论坛 Forum</b> Material X - 可持续未来材料研讨 Material X: NextGen Sustainable Solutions	第一部分: 开幕致辞 第二部分: 主题演讲 Part 1: Opening Introduction Part 2: Keynote Speech	普通话 * Mandarin*
15:35 - 16:05 5.1-K48	<b>研讨会 Seminar</b> 可持续化学品解决方案: ZDHC 化学 物质零排放认证 Sustainable Chemical Management: ZDHC Zero Discharge of Hazardous Chemicals	郝瑞肖, 北京爱科赛尔认证中心有限公司 生态产品事业部, 运营经理 Hao Ruixiao, Ecoproduct BU Manager, Beijing ECOCERT Certification Centre Co Ltd	普通话 * Mandarin*
16:10 - 16:40 5.1-K48	<b>研讨会 Seminar</b> 欧盟可持续产品生态设计法规 (ESPR) 概览 EU Eco-design for Sustainable Products Regulation (ESPR) - Overview 产品碳足迹、碳中和——助力纺织行 业可持续发展 Product Carbon Footprint, Carbon Neutrality - Empowering the Sustainable Development of the Textile Industry	胡年睿, 天祥集团纺织及鞋事业部, 技术副经理 Nina Hu, Assistant Technical Manager, Intertek, Softlines 仇彬鸿, 天祥集团绿色环境部, 副总经理 Joyce Qiu, Assitant General Manager, Intertek, Green Initiatives Department	普通话 * Mandarin*
16:45 - 17:15 5.1-K48	<b>研讨会 Seminar</b> 欧美新法规环境下的供应链追溯 Supply Chain Traceability in the New Regulatory Landscape	陈德宏, TextileGenesis (简称 TG 公司, 为 Lectra 旗下企业), 大中华区总监 Simon Chen, Greater China Regional Lead, TextileGenesis, a Lectra Company	普通话 * Mandarin*



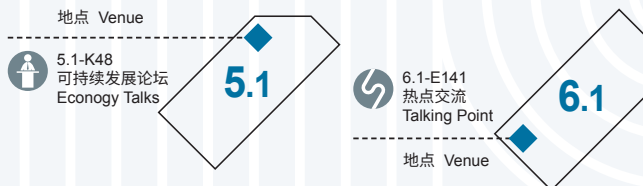

## 2025.3.12

时间 Time 地点 Venue	主题 Topic	讲者 Speakers	语言 Language
10:15 - 10:45 5.1-K48	<b>研讨会 Seminar</b> 中国纺织服装企业 ESG 转型实践与挑战 The Practice and Challenges of ESG Transformation of Chinese Textile and Apparel Enterprises	吴艳, 上海棉丰达商业管理有限公司, 总经理 Sherry Wu, General Manager, Shanghai Mianfengda Business Management Co Ltd	普通话 * Mandarin*
10:30 - 12:00 6.1-E141	<b>论坛 Forum</b> 纺织服装行业产品碳足迹发布 Release of Product Carbon Footprint in the Textile and Apparel Industry	第一部分: 开幕致辞 第二部分: 主题演讲 Part 1: Opening Speech Part 2: Keynote Speech	普通话 * Mandarin*
10:50 - 11:05 5.1-K48	<b>研讨会 Seminar</b> 协同创新——共建纺织产业永续未来 Advancing Sustainability in the Textile Industry - Collaborative Strategies for a Greener Future	陈念群, 香港纺织及成衣研发中心总监 (业务拓展) Katherine Chan, Director of Business Development, HKRITA	普通话 * Mandarin*
12:10 - 12:40 6.1-E141	<b>研讨会 Seminar</b> 认证助力纺织服装企业创新 Certification Facilitates Innovation in Textile and Garment Enterprises	刘良合, 中联品检 (北京) 技术集团有限公司, 认证事业部 副总监 Lianghe Liu, Deputy Director of the Certification Division, United Testing Services (Beijing) Technology Group Co Ltd	普通话 * Mandarin*
12:55 - 13:25 5.1-K48	<b>研讨会 Seminar</b> “regenagri” 再生 / 生态农业标准: 纺织业可持续发展的新动力 regenagri: New Trend for Sustainable Development in the Textile Industry	陈若翰先生, 世优认证 (上海) 有限公司, 评审部经理 Ron Chen, Certifier, Control Union Certification (Shanghai) Co Ltd	普通话 * Mandarin*
14:15 - 14:45 5.1-K48	<b>研讨会 Seminar</b> 时尚行业 ESG 目标与可持续化学品管理 ESG Goals and Sustainable Chemical Management in the Fashion Industry	赵帅, 通标标准技术服务 (上海) 有限公司, 互联与产品·时尚与服饰科技服务全球技术创新部项目经理 Daniel Zhao, Project Manager, Connectivity and Products, Softlines Service Global Technical Innovation, SGS-CSTC Standards Technical Services (Shanghai) Co Ltd	普通话 * Mandarin*
14:55 - 16:25 5.1-K48	<b>论坛 Forum</b> 全球纺织行业的循环经济——机遇与挑战 Circularity in the Global Textile Industry - Opportunities and Challenges	赵芳美, 北京爱科赛尔认证中心有限公司, 可持续发展产品事业部经理及华东分中心负责人 Eva McGeorge, 全球市场高级总监, 兰精集团 Morgane Parizot, Redress 教育总监 黄伟基 Fangmei Zhao, Ecoproduct BU Product Manager and East China Office Manager, Beijing ECOCERT Certification Centre Co Ltd Eva McGeorge, Senior Global Marketing Director, Lenzing Group Morgane Parizot, Strategic Education Director, Redress Justin Huang	英语 * English*
16:30 - 17:00 5.1-K48	<b>研讨会 Seminar</b> 以不变应万变——伊士曼 Naia™ Renew 短纤提供跨场景穿着的可持续解决方案 Versatility in Every Moment - Eastman Offers Sustainable Solutions for Cross-scenario Wear with Naia™ Renew Staple Fiber	陈喆炜, 伊士曼 (中国) 投资管理有限公司, 纺织事业部亚太区商务开发高级经理 Kevin Chen, AP Business Development Senior Manager, Textiles, Eastman Chemical (China) Co Ltd	普通话 * Mandarin*

\* 提供普通话 ↔ 英语同声传译

\* Mandarin Chinese ↔ English Simultaneous Interpretation will be provided

# 活动总览 – 市场信息及营销策略

## EVENT OVERVIEW – MARKET INFORMATION & BUSINESS STRATEGIES

**2025.3.11**

时间 Time 地点 Venue	主题 Topic	讲者 Speakers	语言 Language
10:30 - 10:55 6.1-E141	<b>论坛 Forum</b> 从设计到生产的数字色彩管理——赋予色彩的技术力量 Digital Color Management from Design to Production - Empowering Technology for Color	Detlev Pross, 上海元彩科技有限公司首席策略官 Detlev Pross, Chief Strategy Officer, Coloro	英语 * English*
10:55 - 11:20 6.1-E141	<b>论坛 Forum</b> 数据 & AI 助力面料色彩: 天猫 TMIC 服饰新趋势 Data & AI Application on Texture & Color: TMALL TMIC Apparel Trend	皓米, TMIC 服饰运动负责人 Emmy, Manager, TMIC Apparel & Sports	普通话 * Mandarin*
11:20 - 11:45 6.1-E141	<b>论坛 Forum</b> 穿搭新风尚: 服饰赛道下的未来消费趋势洞察 New Fashion Trends in Dressing: Insights into Future Consumption Trends in the Fashion Industry	易凡, 魔镜洞察高级分析师 Fan Yi, Senior Analyst, Moojing Market Intelligence	普通话 * Mandarin*
11:45 - 12:05 6.1-E141	<b>论坛 Forum</b> 打造产品 - 商品双循环——以匠心铸就产品内核, 实现服企商品最优价值转化 Create a Product-Commodity Double Cycle - Cast the Product Core with Ingenuity, and Achieve the Optimal Value Transformation of Service Enterprises	冯恺, 赛趋科软件(上海)有限公司资深业务顾问 William Feng, Senior Business Consultant, Centric Software	普通话 * Mandarin*
12:05 - 12:30 6.1-E141	<b>论坛 Forum</b> AI 视觉检测在纺织行业的应用实践 Application Practice of AI Vision Inspection in the Textile Industry	朱如江, 南通巨联数字科技有限公司副总经理 Rujiang Zhu, Deputy General Manager, Nantong Julian Digital Technology Co Ltd	普通话 * Mandarin*
12:50 - 13:50 6.1-E141	<b>研讨会 Seminar</b> 质享人群崛起 新时代“讲究人”的家居趋势新洞见	小红书家纺及面料窗帘行业运营负责人 维莉 小红书商业家居行业 CBD 子歌	普通话 * Mandarin*
14:00 - 15:00 6.1-E141	<b>论坛 Forum</b> 东方国色, 生生不息《中国传统色应用色卡》发布 The Release of Classical Color Collections of China	张玮, Coloro 色彩应用研究院院长, 中国纺织信息中心副主任 黄荣华, 李子柒“春晚战袍”染制者、植物染技艺非遗传承人 Zhang Wei, Director, Coloro Institute; VP CTIC Huang Ronghua, Inheritor of The Intangible Cultural Heritage of Plant Dyeing Craft	普通话 * Mandarin*
15:00 - 15:20 6.1-E141	<b>论坛 Forum</b> The Thinner The Better——优可丝纤柔助力效率与品质双升级 The Thinner The Better - Ecocosy Improve the Efficiency and Quality	颜荟, 赛得利市场高级经理 Effy Yan, Marketing Senior Manager, Sateri	普通话 * Mandarin*



6.1-E141  
热点交流  
Talking Point

6.1

地点 Venue

15:20 - 15:40 6.1-E141	<b>论坛 Forum</b> 以功能与绿色纤维赋能品牌可持续发展 Empowering Brand Sustainable Development with Functional and Green Fibers	阙丹, 福建永荣锦江股份有限公司, 品牌与商务部总监 Que Dan, Director, Brand and Commercial Department, Fujian Yongrong Jinjiang Co Ltd	普通话* Mandarin*
15:40 - 16:00 6.1-E141	<b>论坛 Forum</b> 丝柔纺: 天然纱线实现可持续功能性解决方案 Silrospun: Natural Yarns for Sustainable Functional Solutions	栾熙忠, 卡莱多(上海)纺织科技有限公司, 董事 Luke, Director, Karado (Shanghai) Textile & Garment Co Ltd	普通话* Mandarin*
16:00 - 16:20 6.1-E141	<b>论坛 Forum</b> 「在风中」系列——AI 仿印经绸系列面料全新发布 The In the Wind Series - AI Imitation Printed Silk Series Fabric New Release	蒋璐, 浙江凯喜雅智纺科技有限公司, 总经理 Lulu, General Manager, Zhejiang Cathaya Intelligent Textile Technology Co Ltd	普通话* Mandarin*
16:20 - 16:40 6.1-E141	<b>论坛 Forum</b> 解码“真”需求, 织就未来——高端裤装面料产品创新之路 Decoding the "True" Demand, Weaving the Future - The Path of Innovation for High-end Trousers Fabric	王堃, 广州帛璟纺织品有限公司, 总经理 Wang Kun, General Manager, Guangzhou Bojing Textile Co Ltd	普通话* Mandarin*
16:40 - 17:00 6.1-E141	<b>论坛 Forum</b> 重构与新生: 刺绣行业从传统制造到智能创造的跃升 Reconstruction and New Life: The Leap from Traditional Manufacturing to Intelligent Creation in the Embroidery Industry	王明亮, 绍兴明晗绣品有限公司, 总经理 Wang Mingliang, General Manager, Shaoxing Minghee Embroidery Co Ltd	普通话* Mandarin*
17:00-17:20 6.1-E141	<b>论坛 Forum</b> 科技、文化与可持续融入牛仔面料的创新变革 Innovation and Transformation of Technology, Culture, and Sustainable Integration into Denim	涂强, 广州市谊兴纺织有限公司, 品牌营销总监 Tu Qiang, Brand Marketing Director, Guangzhou Winwin Textile Co Ltd	普通话* Mandarin*

\* 提供普通话 ↔ 英语同声传译

\* Mandarin Chinese ↔ English Simultaneous Interpretation will be provided

# 活动总览 – 技术

## EVENT OVERVIEW – TECHNOLOGY AND SOLUTIONS

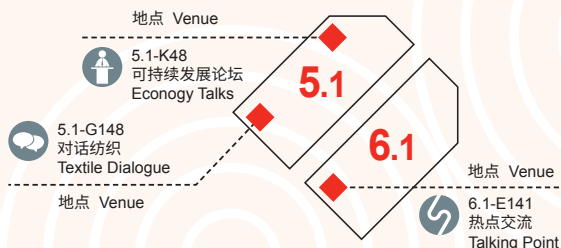

2025.3.12

时间 Time 地点 Venue	主题 Topic	讲者 Speakers	语言 Language
11:15 - 12:45 5.1-K48	<b>论坛 Forum</b> 创新铸就可持续未来——突破挑战、 协同合作、深化影响 Shaping the Future of Sustainability Through Innovation - Overcoming Obstacles, Fostering Cooperation, and Driving Impact	主持人: Karl Borgschulze, 咨询服务国际董事总经理 嘉宾: 陈念群, 香港纺织及成衣研发中心总监 (业务拓展) 马磊, 伊士曼 (中国) 投资管理有限公司, 亚太区 集团可持续发展经理 Denier Qi, 达利 (中国) 有限公司, Advance Textiles 市场总监 陈德宏, TextileGenesis (简称 TG 公司, 为 Lectra 旗下企业), 大中华区总监 Moderator: Karl Borgschulze, Managing Director, Consulting Service Internationa Speakers: Katherine Chan, Director of Business Development, HKRITA Lei Ma, AP Sustainability Manager, Eastman Denier Qi, Marketing Director of Advance Textiles, High Fashion (China) Company Limited Simon Chen, Greater China Regional Lead, TextileGenesis, a Lectra company	英语 * English*
13:35 - 14:05 5.1-K48	<b>研讨会 Seminar</b> 持续迭代的兰精创新纤维满足多元的 市场需求 Continuously Iterating Lenzing Innovative Fibers to Meet Diverse Market Demands	任雯洁, 兰精集团中国区业务拓展经理 Vivian Ren, Business Development Manager, Lenzing Group	普通话 * Mandarin*
14:05 - 16:30 5.1-G148	<b>论坛 Forum</b> 2025 国际纺织产业数字化应用趋势 论坛 2025 International Textile Industry Digital Application Trend Forum	主持人: 钟跃崎, 东华大学纺织学院教授 嘉宾: 孙伊, 上海元彩科技有限公司, 数字色彩专家 孙亮, 飞弗信息科技 (上海) 有限公司总经理 林广川, 广东匡教科技有限公司商务总监 丁腾飞, 苏州飞榴科技有限公司销售 VP Moderator: Yueqi Zhong, Professor, School of Textiles, Donghua University Speakers: Yi Sun, Digital Color Expert, Coloro Liang Sun, General Manager, Feifu Information Technology (Shanghai) Co Ltd Guangchuan Lin, Business Director, Guangdong Quaternion Technology Ltd Tengfei Ding, Sales VP, Feiliu (Shanghai) Information Technology Co Ltd	普通话 * Mandarin*
13:30 - 16:00 6.1-E141	<b>论坛 Forum</b> 纺织论坛 (春季) Intertextile Forum (Spring)	第一部分: 领导致辞 第二部分: 主题演讲 第三部分: 主题对话 Part 1: Opening Address Part 2: Keynote Speech Part 3: Thematic Dialogues	普通话 / 英语 * Mandarin / English*
16:30 - 17:10 6.1-E141	<b>研讨会 Seminar</b> 科技赋能 · 新质丝绸 Technology Empowerment · New Quality Silk	李鹏, 浙江凯喜雅国际股份有限公司, 国家级工业 设计中心主任 Peng Li, Manager of National-level Industrial Design Center, Zhejiang Cathaya International Co Ltd	普通话 * Mandarin*

\* 提供普通话 ↔ 英语同声传译

\* Mandarin Chinese ↔ English Simultaneous Interpretation will be provided

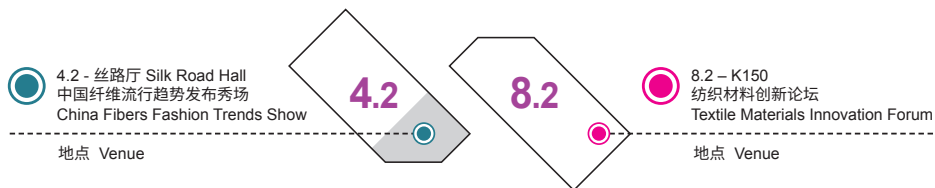

## 中国纤维流行趋势发布会及企业产品发布会 China Fibers Fashion Trends and Enterprise Product Launch

2025.3.11

时间 Time	活动主题 Content	发布单位 Company
10:30 - 11:40 ● 4.2 丝路厅 Silk Road Hall	桐昆·中国纤维流行趋势 2025/2026 发布会 Tongkun · China Fibers Fashion Trends 2025/2026 Show	中国化学纤维工业协会 China Chemical Fibers Association 东华大学 Donghua University 中国棉纺织行业协会 China Cotton Textile Association 桐昆集团股份有限公司 Tongkun Group Co Ltd
14:00 - 14:45 ● 4.2 丝路厅 Silk Road Hall	泰森·赛得利 漫步针织星辰海 TAISUM · Sateri Across the Fabric Universe	泰森布业 TAISUM Textile 赛得利集团 Sateri Group

## 纤维新视界——纺织材料创新论坛 New Fiber New World - Textile Materials Innovation Forum

2025.3.11

### 发布会 Launch

时间 Time	活动主题 Content	发布单位 Company
13:20 - 13:50 ● 8.2-K150	“标”定健康，“烯”启未来 ——石墨烯多功能复合纤维吊牌发布仪式 Tagging Health, Sparking Future - Launch Ceremony of Graphene Multifunctional Composite Fiber Tags	杭州高烯科技有限公司 Hangzhou Gaoxi Technology Co Ltd
14:00 - 14:25 ● 8.2-K150	纤启永续，绿动未来 ——浙江佳人新材料有限公司新产品发布会 Fiber Ignites Sustainability, Green Powers Future - Zhejiang Jiaren New Materials Co Ltd New Product Launch Event	浙江佳人新材料有限公司 Zhejiang Jiaren New Materials Co Ltd
14:40 - 15:20 ● 8.2-K150	全生物基聚酯，“碳”索纤维未来 ——德福伦 BioFleax™ PEF 短纤产品联合发布会 100% Bio-based Polyester, Where Nature Meets Tomorrow - Different BioFleax™ PEF Staple Fibers Product Joint Launch Event	上海德福伦新材料科技有限公司 Shanghai Different Advanced Material Company Limited 合肥利夫生物科技有限公司 Hefei Leaf Biotech Co Ltd

### 中国纤维流行趋势深入解读 China Fibers Fashion Trends Deep Interpretation Forum

时间 Time	活动主题 Content	公司 / 演讲人 Company / Speaker
15:30 - 16:20 ● 8.2-K150	中国纤维流行趋势 2025/2026 深度解读 Interpretation of China Fibers Fashion Trends 2025/2026	王华平，东华大学材料科学与工程学院 Mr Wang Huaping, College of Materials Science and Engineering, DHU
16:20 - 17:00 ● 8.2-K150	解决问题的设计 Design Problem-solving	邵新艳，北京服装学院服装艺术与工程学院 Ms Shao Xinyan, Beijing Institute of Fashion Technology School of Fashion

2025.3.12

### 绿色低碳发展专场 Green & Low-carbon Development Forum

时间 Time	活动主题 Content	公司 / 演讲人 Company / Speaker
10:00 - 10:15 ● 8.2-K150	生物基原纱抗菌聚酯纤维 Bio-based Virgin Antibacterial Polyester Fiber	徐飞，浙江桐昆新材料研究院有限公司 Mr Xu Fei, Zhejiang Tongkun Institute for Advanced Materials Co Ltd

 M802 会议室  
M802 Meeting Room

10:15 - 10:30 8.2-K150	海藻纤维在新材料创新领域的最新突破 The Latest Breakthroughs of Alginate/Seaweed Fiber in the Field of New Material Innovation	刘春梅, 山东海纤生物科技材料有限公司 Ms Liu Chunmei, Shangdong Healcell Biomaterials Technology Co Ltd
10:30 - 10:45 8.2-K150	AC-TEX® 相变调温纤维长丝量产及应用 Mass Production and Applications of AC-TEX® Phase Change Temperature-Regulating Fiber Filament	宋鹏程, 三沐新材料(浙江)有限公司 Mr Song Pengcheng, Sanmu New Materials (Zhejiang) Co Ltd
10:45 - 11:00 8.2-K150	碳捕集聚酯纤维——低碳与创新的融合 Carbon-Capturing Polyester Fiber - The Fusion of Low Carbon and Innovation	缪佳, 江苏盛虹化纤新材料有限公司 Mr Miao Jia, Jiangsu Shenghong Chemical Fiber New Material Co Ltd

## 发布会 Launch

时间 Time	活动主题 Content	发布单位 Company
11:15 - 12:15 8.2-K150	中国纱线流行趋势 2025/2026 发布会 China Yarns Fashion Trends 2025/2026	中国棉纺织行业协会 China Cotton Textile Association
13:00 - 13:40 8.2-K150	莱赛尔纤维应用趋势主题论坛 Thematic Forum on the Application Trends of Lyocell	中国化学纤维工业协会莱赛尔纤维分会 China Chemical Fibers Association Lyocell Branch
14:00 - 14:40 8.2-K150	再生循环, 绿动未来 ——FixDye 环保再生涤纶长丝发布会 Innovative Technology, Green Future - FixDye Recycled Polyester Filament Yarn Launch Event	江苏佩浦科技集团有限公司 Jiangsu REO-ECO Technology Group Co Ltd

## 中国纤维流行趋势入选纤维专场 China Fibers Fashion Trends Issue Products Forum

时间 Time	活动主题 Content	公司 / 演讲人 Company / Speaker
15:00 - 15:15 8.2-K150	品质铸就时尚, 科技引领发展 ——桐昆·中国纤维流行趋势产品开发与应用实践 Quality Crafts Fashion, Technology Drives Development - Tongkun • China Fiber Trend: Products Development and Application Practices	李国元, 桐昆集团股份有限公司 Mr Li Guoyuan, Tongkun Group Co Ltd
15:15 - 15:30 8.2-K150	生物基尼龙材料在纺织中的创新应用与实践 Innovative Application and Practice of Bio-based Nylon Materials in Textiles	郑文昌, 黑龙江伊品新材料有限公司 Mr Zheng Wenchang, Heilongjiang Eppen New Materials Co Ltd
15:30 - 15:45 8.2-K150	ReVisco™ Black 双重技术链下的循环新生 ReVisco™ Black Dual Technology Chain for Circular Renewal	刘辉, 唐山三友集团兴达化纤有限公司 Mr Liu Hui, Tangshan Sanyou Group Xingda Chemical Fibre Co Ltd
15:45 - 16:00 8.2-K150	绿色纤维, 编织未来: 奥神® 可持续产品介绍 Green Fiber, Weaving Tomorrow: AOSHEN® Sustainable Product Introduction	曾登, 连云港杜钟新奥神氨纶有限公司 Mr Zeng Deng, LDZ New Aoshen Spandex Co Ltd
16:00 - 16:15 8.2-K150	“卷”时代下的好材料与好面料 Good Materials and Fabrics in the Era of "Rolls"	孟红军, 江苏三联新材料股份有限公司 Mr Meng Hongjun, Jiangsu Sanlian New Material Co Ltd
16:15 - 16:30 8.2-K150	可感知暖热纤维材料的创新开发和应用 Innovative Applications of Thermally Sensitive Fiber Materials	宋慎群, 江苏康溢臣生命科技有限公司 Mr Song Shenqun, Jiangsu KECens Life Science & Tenchnology Co Ltd

## 交流会 Exchange Meeting

2025.3.11

时间 Time	活动主题 Content	公司 / 演讲人 Company / Speaker
15:15 - 17:15 M802 会议室 Meeting Room	中国纤维流行趋势 2025/2026 ——纤·破界 / 无界入选纤维应用对接交流会 China Fibers Fashion Trends 2025/2026 - Fiber • Beyond the Limit / Without Limit Application Exchange Meeting	流行趋势研究与推广工作室 Fashion Trend Research and Promotion Studio 时尚趋势咨询机构 POP 趋势 Fashion Trend Consulting Agency

## 同期活动场地 Fringe Programme Venues

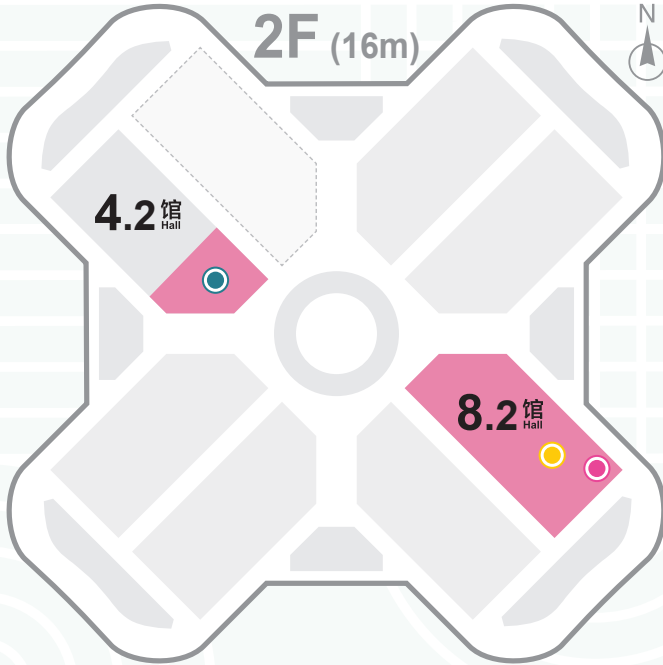

-  中国纤维流行趋势发布秀场  
(4.2馆 丝路厅)  
China Fibers Fashion Trends Show  
(Hall 4.2 - Silk Road Hall)
-  中国纤维流行趋势 /  
中国纱线流行趋势  
(8.2-G109)  
China Yarns Fashion Trends /  
China Fibers Fashion Trends  
(8.2-G109)
-  纺织材料创新论坛  
(8.2-K150)  
Textile Materials Innovation Forum  
(8.2-K150)

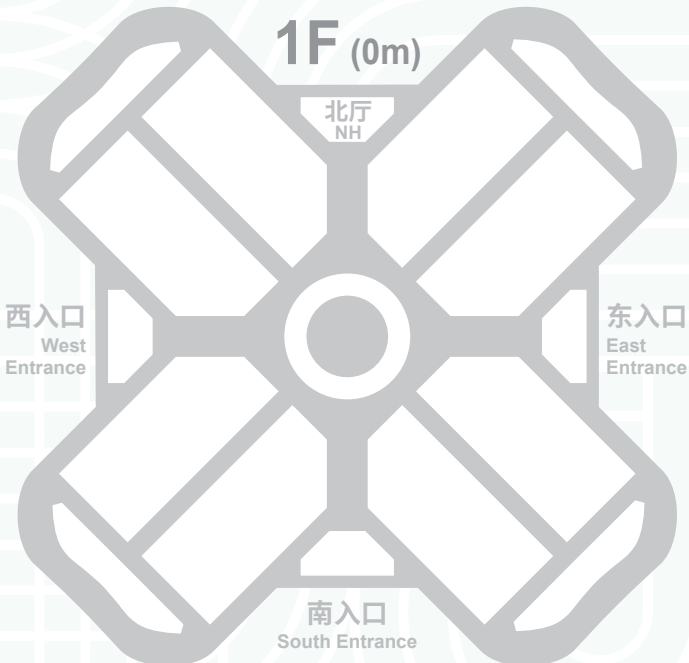

# yarnexpo

中国国际纺织纱线(春夏)展览会  
China International Trade Fair for Fibres and Yarns

2025.3.11 – 13

8.2<sub>Hall</sub> 馆

国家会展中心 (上海)

Hall 8.2, National Exhibition and  
Convention Center (Shanghai), China

## 同期活动

Fringe Programme



messe frankfurt



研讨会日程  
Seminar schedule