

# intertextile

## SHANGHAI apparel fabrics

中国国际纺织面料及辅料(春夏)博览会  
China International Trade Fair for Apparel Fabrics  
and Accessories – Spring Edition

### 2024.3.6 – 8

国家会展中心 (上海)

National Exhibition and Convention  
Center (Shanghai), China

## 同期活动

### Fringe Programme



研讨会日程  
Seminar schedule



messe frankfurt

# 同期活动场地 Fringe Programme Venues

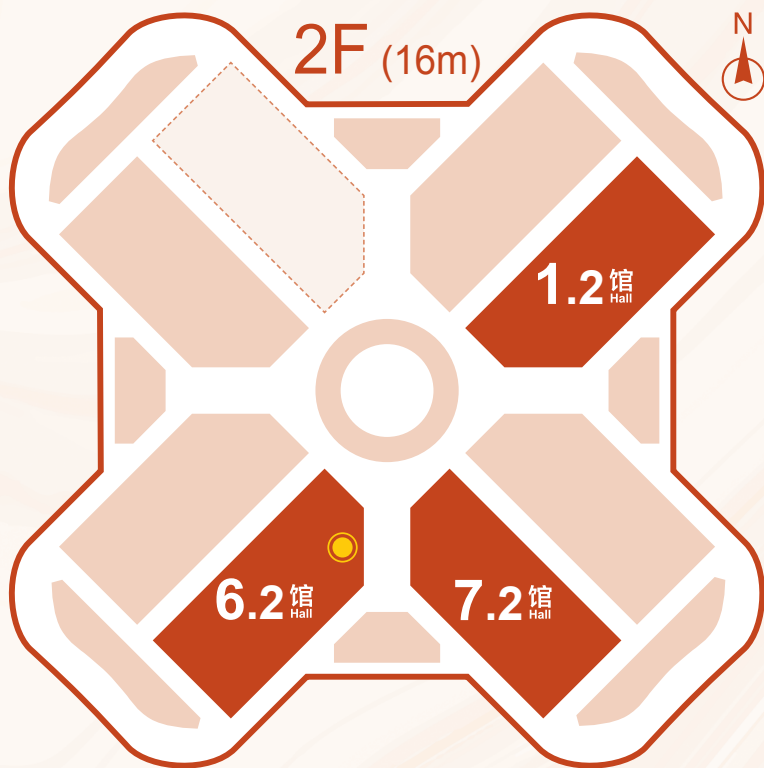

- 流行趋势  
Trend Forum
- 新技术创新空间  
Innotex Space
- 可持续创新专区  
Sustainable Zone
- 数字时尚创新空间  
Digital Fashion Innovation Space
- 热点交流  
Talking Point
- 对话纺织  
Textile Dialogue
- 前沿分享  
Forum Space

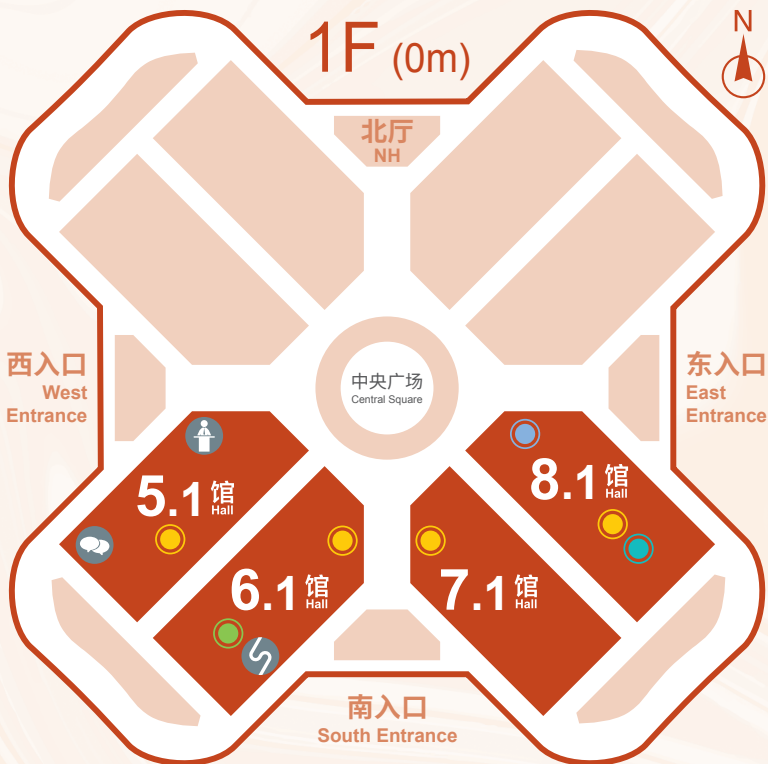

## 同期活动简介

## FRINGE PROGRAMME INTRODUCTION

中国国际纺织面料及辅料（春夏）博览会的同期活动将横跨三天展期，以 4 大主题分类，聚焦及塑造服装及纺织贸易行业的未来。我们邀来行业专家及企业参与 26 场研讨会、6 场论坛分享及 3 场产品发布会，为买家及观众带来行业见解。

The 3-day fringe programme will be categorised into FOUR key themes that shape the future of apparel and the textile trade industry. Industry professionals and our exhibitors will conduct 26 seminars, 6 themed forums and 3 production presentations to provide insight for the exhibitors and buyers with highlighted program as follows:

### 流行趋势

#### Design and Trend

国际知名的行业专家将进行多场研讨会及专题小组会议揭示 2025 春夏面料及色彩趋势。全面的流行趋势发布区将介绍各种面料的设计与潮流趋势。

Internationally renowned industrial specialists will offer various seminar and panel discussion sessions to reveal SS 2025 fabrics and color trend. A comprehensive trend forum revealing the latest in design trends through fabric displays and seasonal trend stories.

- Intertextile 2025 春夏流行趋势解析 Intertextile Trends Spring/Summer 2025 P 02
- 2025 春夏中国纺织面料流行趋势论坛 SS25 Fabrics China Trend Forum P 04

### 市场信息及营销策略

#### Market Information & Business Strategies

2024 纺织产业数字化应用趋势论坛议题依旧将紧跟纺织服装产业数字化创新应用趋势，聚焦于纺服数字化研发设计、智慧生产和制造、数字营销等核心环节展开系列案例分享和数字化升级变革的话题讨论。

2024 Textile Industry Digital Application Trend Forum will focus on textile and clothing R&D and design, smart production and manufacturing, and digital marketing. There will be a series of case sharing and topic discussions on digital transformation.

- 2024 年第四届纺织工业设计创新论坛 2024 The Fourth Innovation Forum for Textile Industrial Design P 06
- 2024 纺织产业数字化应用趋势论坛 2024 Textile Industry Digital Application Forum P 08

### 技术

#### Technology and Solution

纺织论坛将以“科创未来：新技术新动能新业态”为题，探讨该如何用科技创新与技术应用为产业供给质量与效率注入新活力，如何将前沿技术落地为先进生产力，将科技创新与商业价值进行最大转化。

intertextile FORUM will discuss how science and innovation can inject new vitality into the textile industry to improve its quality and efficiency, and how should cutting-edge technologies be translated into advanced productivity to maximize the commercial value of technical innovation.

- 科创未来：新技术 新动能 新业态  
 Future Based on Science and Innovation: New Technologies, New Impetus, New Business Formats P 10

### 可持续发展议题

#### Sustainability Issue

研讨会将介绍最新的可持续发展相关趋势、动向、标准及规定之更新。论坛则探索正在重塑时尚格局的革命性技术和可持续实践，推动时尚产业迈向更环保和循环的转变。

Seminars will introduce the latest sustainable trend, standard and regulations updates. Forum will explore the revolutionary technologies and sustainable practices that are reshaping the fashion landscape. Be part of the conversation driving the shift towards a more eco-friendly and circular fashion industry.

- 纺织创新之路：展示纺织品回收的未来  
 Threads of Innovation: Unveiling the Future of Textile Recycling P 12
- “可持续未来材料”探索与展望 Future Materials: Sustainable Exploration and Prospect P 14

## 重点活动 – 流行趋势

### FEATURED EVENTS – DESIGN AND TREND



#### 流行趋势展示区 5.1-E106 Trend Forum 5.1-E106

潮流导向委员会自 1998 年成立，委员会各成员来自世界各地的时尚之都，遍布欧洲、亚洲及美国等全球主要成衣出口市场，并致力为设计师及纺织业专才提供宝贵的市场研究及推广工具，协助他们紧贴未来的时装潮流而进行设计及生产。每一季，委员会都会结合彼此的专业知识和地区实力，利用展商所提交的面料以鲜明的主题刻划未来潮流及时装材料趋势。

The *Directions* Trend Committee was established in 1998, committee members come from fashion capitals of the major export markets for international garment trade: New York, Milan, Paris and Tokyo, has provided an invaluable research and marketing tool to designers and garment professionals, helping them steer their designs and manufacturing process in line with coming fashion seasons. Each season, they combine their expertise and local influences to come up with the themes that tell the story of tomorrow's apparel fabric trends and present at the Trend Forum through fabrics from exhibitors.

#### 2025 春夏季度主题：起伏跌宕 Spring/Summer 2025 Seasonal theme: TURBULENCE

一个复杂的新世界即将展开。我们在虚拟世界中的活动范围不断扩大，新的情感也随之涌现。在发掘情感和追求身心健康的过程中体现自我放纵和自我表达。

现代和平主义者在恒常的生活和流动的二元对立间徘徊，将陌生与熟悉、几何与有机、自然与人工、简约与奢华相混合，走遍大地追寻一种亲密融合的感觉。他们以非传统的方式导出自由表达。利用热闹和夸张的巡游来抗行压抑。致力于将他们拥有的、可改造的和可回收的一切回馈地球。

不论是出于生态意识和反对时装过度生产的考虑，或是高度依赖财政资源并受控于社交媒体和有影响力的人物，时尚界必须确定如何满足消费者的要求。

展望未来，时尚界将展现积极和感性的新价值观，面对潜在的起伏，以坚定的信念，引领人们走向更美好的未来。

##### 四大主题：

- 优雅 • 沉浸 • 转换 • 呼唤

A complex new world is about to unfold. Our scope of activities expands within the virtual world and sees new EMOTIONS emerge. Self-indulgence and self-expression are both reflected in emotional investigation and in the quest for physical and mental WELLNESS.

Suspended between the concreteness of everyday life and the fluidity of dualisms and contrasts, mixing the foreign and the familiar, the geometric and the organic, the natural and the artificial, minimalism and extravagance, modern pacifist PIONEERS scour the continents for a sense of togetherness and generosity. They channel free expression through their unconventional perspective. They fight oppression by means of festive and flamboyant parades. They commit to our planet by making do with what they have, what they can reclaim and what they can recycle.

Fashion must ascertain how to handle consumers' requests, either driven by ecological consciousness and the fight against fashion overproduction, or highly dependent on financial resources and in the grip of social media and influencers.

Going forward fashion will embody the new values of POSITIVITY and sensibility, anchored in trust, to face the emergence of potential TURBULENCE, helming the way to a better future.

##### Four themes will be presented:

- GRACE • IMMERSIVE • SWITCH • VOICES

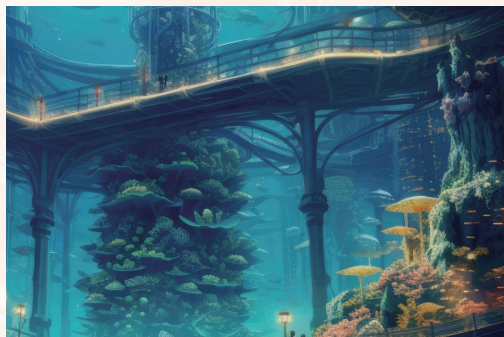

地点 Venue



5.1-E106  
流行趋势展示区  
Trend Forum

5.1

地点 Venue



5.1-K149  
对话纺织  
Textile Dialogue

## Intertextile 流行趋势讲解 Intertextile Trend Introduction



2025 年春夏潮流趋势之首席设计师为美国 DONEGER | TOBE，其创作总监 Kai Chow 先生将全面介绍 Intertextile 流行趋势，包括各种面料的设计与潮流趋势。

The designer for SS 2025 Trend Forum is DONEGER | TOBE from USA. Mr Kai Chow, Creative Director, will introduce the Intertextile Trend, the latest design trends and seasonal trend stories.

### 2024.3.6

10:40 - 11:30

5.1-K149

Intertextile 2025 春夏流行趋势解析  
Intertextile Trends Spring/Summer 2025

13:00 - 13:30

5.1-E106

流行趋势讲解 – 第一节  
Trend Forum Introduction Tour – Session 1

15:30 - 16:00

5.1-E106

流行趋势讲解 – 第二节  
Trend Forum Introduction Tour – Session 2

### 2024.3.7

11:00 - 11:30

5.1-E106

流行趋势讲解 – 第三节  
Trend Forum Introduction Tour – Session 3

\* 以上所有讲解将以英文进行，并提供中文翻译。

\* All above sessions will be conducted in English, Mandarin interpretation will be provided.



## 重点活动 – 流行趋势

### FEATURED EVENTS – DESIGN AND TREND

2025 春夏中国纺织面料流行趋势论坛  
2025SS Fabrics China Trend Forum

论坛  
FORUM



中国纺织面料流行趋势研究结合市场需求，系统化研究色彩、纤维、纱线、面料服装风格、技术以及产品开发方向，运用趋势研究的国际化、专业化和市场化研究力量，指导企业进行精准的趋势应用与产品推广。此次系列趋势论坛演讲嘉宾由中国纺织信息中心流行趋势研究专家、分品类趋势联盟研究专家组成，以2025春夏中国纺织面料流行趋势为引领，结合纺织服装产业链的终端需求，在产品开发、产品企划以及生产实践等多维度进行系统化阐述，展示中国纺织面料流行趋势及分品类趋势的研究成果。

Based on market demand, Fabrics China trend research gathers international, professional, and market-oriented research resources to systematically study colors, fibers, yarns, fabrics, apparel styles, technologies, and product development directions, so as to guide enterprises to promote new products on the basis of latest trends application. The speakers of this forum are trend research experts from China Textile Information Center and sub-category trend alliances. Combining the needs of the textile and apparel industry chain, experts will elaborate on product development, product planning, and production practice based on the 2025SS Fabrics China trend research, showing related research results and category trends.

国内流行趋势区位置：

- 6.1 号馆 可持续时尚趋势区 (6.1-E12)
- 6.2 号馆 时尚概念趋势区 (6.2-E16)
- 7.1 号馆 牛仔流行趋势区 (7.1-E12)
- 8.1 号馆 科技 & 功能趋势区 (8.1-E106)

Location of domestic trend forums:

- 6.1H Sustainable Fashion Forum (6.1-E12)
- 6.2H Fashion Focus Trend Forum (6.2-E16)
- 7.1H Denim Trend Forum (7.1-E12)
- 8.1H Techno Functions Trend Forum (8.1-E106)

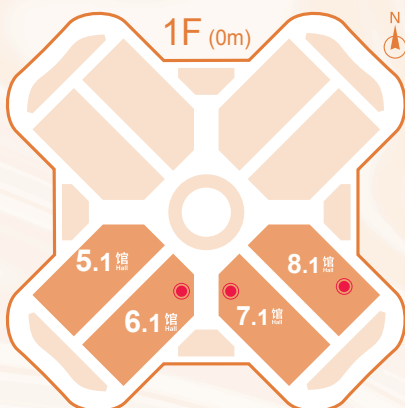
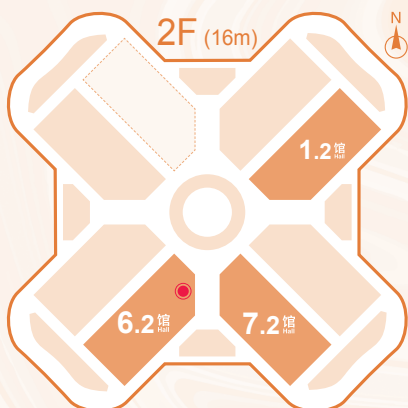

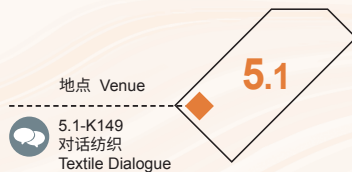
**2024.3.6**

时间 Time	主题 Topic	讲者 Speaker
14:00 - 14:40	2025 春夏中国纺织面料流行趋势——生活方式 2025SS Fabrics China Trend - Lifestyle	渠梦玮, 中国纺织信息中心流行趋势部趋势研究员 / FASHION INSIGHT 编辑 Mengwei Qu, Trend Researcher of Trends Department, China Textile Information Center
14:40 - 15:10	2025 春夏中国艺术染整流行趋势 2025SS Chinese Dyeing & Finishing Trend	中国纺联艺术染整与现代扎染流行趋势研究中心 罗竞杰, 东华大学服装与艺术设计学院服装与服饰专业负责人 东华·江苏华艺艺术染整科技创新中心主任 Fabrics China Trend Research Center - Artistic Dyeing & Finishing and Modern Tie Dyeing Jingjie Luo, Director of Apparel & Accessories Dept, College of Fashion and Design of Donghua University Director of Donghua · Jiangsu Huayi Artistic Dyeing & Finishing Innovation Research Center
15:10 - 15:40	新技术、新材料、新价值——解读 2025 春夏流行纱线新趋势 New Technology, New Materials, New Value - Interpreting the New Trend of Popular Yarns in 2025SS	中国纺联纺织新材料纱线流行趋势研究中心 朱培, 山东联润新材料科技有限公司总经理助理 Fabrics China Trend Research Center - New Fiber-based Yarn Pei Zhu, General Manager Assistant, Shandong Long Run Textile Co Ltd
15:40 - 16:10	2025 春夏精毛纺女装面料流行趋势 2025SS Fashion Trend of Worsted Textiles for Womenswear	中国纺联女装精毛纺面料流行趋势研究中心 李雅, 江苏丹毛纺织股份有限公司面料设计师 Fabrics China Trend Research Center - Worsted Textiles for Womenswear Ya Li, Textiles Designer, Jiangsu Danmao Textile Co Ltd
16:10 - 16:30	洛杉矶春夏牛仔市场及趋势更新 Los Angeles Market and Trend Update for Denim in Spring / Summer	Bryan Hoyos, 广东前进牛仔布有限公司美国市场总监 Bryan Hoyos, USA Marketing Director, Advance Denim Co Ltd

**2024.3.7**

时间 Time	主题 Topic	讲者 Speaker
10:20 - 11:00	2025 春夏中国纺织面料流行趋势——色彩解析 2025SS Fabrics China Trend - Color Trend	王玢, 中国纺织信息中心流行趋势部趋势研究员 / FASHION INSIGHT 编辑 Bin Wang, Trend Researcher of Trends Department / Editor of FASHION INSIGHT, China Textile Information Center
11:00 - 11:30	2025 春夏图案趋势分析 2025SS Pattern Trend Analysis	洪溶, 中国纺织信息中心时尚智能部运营经理 Rong Hong, Operations Manager of Fashion Intelligence Department, China Textile Information Center
11:30 - 12:00	环保纱线助力健康生活 Eco-friendly Yarn - A Way to Achieve a Healthy Life	中国纺联差别化功能性色纺纱流行趋势研究中心 张淑云, 德州华源集团有限公司配色室主管 Fabrics China Trend Research Center - Functional Colored Spun Yarn Shuyun Zhang, Color Design Director, Dezhou Huayuan Group Co Ltd
12:00 - 12:30	针仿梭不是仿, 而是面料的新物种 Woven-look Knitting, not Merely an Adoption, but an Evolution	中国纺联针织牛仔流行趋势研究中心 秦刚, 恒亮纺织有限公司营销总监 Vincent Qin, Marketing Director, Hengliang Textile Co Ltd
12:30 - 12:50	绿色纤维莱赛尔的应用趋势 Market Application of Lyocell - the New Generation of Green Technology Fiber	王本行, 赛得利集团华东销售经理 Benhang Wang, Sales Manager, Sateri Iyocell

## 重点活动 – 市场信息及营销策略

### FEATURED EVENTS – MARKET INFORMATION & BUSINESS STRATEGIES

2024 年第四届纺织工业设计创新论坛  
2024 The Fourth Innovation Forum for  
Textile Industrial Design

论坛  
FORUM



论坛围绕“设计赋能”为核心，围绕“设计价值、设计理论与方法、设计实践、设计平台”等方面内容，探讨如何构建行业工业设计价值体系，并邀请工业设计创新能力强、发展水平领先的工业设计中心企业代表进行成功案例分享，推动纺织服装工业设计与制造业融合，促进行业工业设计创新力、时尚力和竞争力。

Centered on "design empowerment" and focusing on "design value, design theory and methodology, design practice, and design platform", the forum will extensively discuss how to create a value system for industrial design. It will also invite enterprise representatives from industrial design centers with strong innovation capabilities and top development levels to share their successful cases. In doing so, the forum will promote the integration of industrial design and manufacturing related to the textile and apparel industry, aiming to enhance innovation, fashion and competitiveness of the textile industrial design.

#### 2024.3.6

14:00 - 14:10

##### 论坛致辞

##### Forum Address

徐迎新，中国纺织工业联合会副会长  
中国国际贸易促进委员会纺织行业分会会长

李波，中国纺织工业联合会生产力促进部主任

Xu Yingxin, Vice Chairman of China National Textile and Apparel Council (CNTAC)

Vice President of the Sub-Council of Textile Industry, China Council for the Promotion of International Trade (CCPIT TEX)

Li Bo, Director of Productivity Promotion Department of China National Textile and Apparel Council (CNTAC)





6.1-J104  
热点交流  
Talking Point

地点 Venue

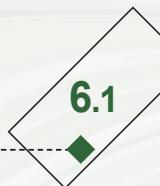

14:10 - 14:40

**演讲题目：设计的价值**

**内容摘要：**探讨工业设计如何有效赋能，实践由内而外打造品牌、由表及里精准定位、由点及面系统创新。

**演讲嘉宾：**林晨晔，上海博路工业设计有限公司副总经理

**Speech Topic: The Value of Design**

**Abstract:** Industrial design can effectively empower development by building the brand from its core, considering the development direction from an external perspective, and implementing systematic innovation from the core to the surface.

**Speaker:** Lin Chenye, Deputy General Manager, Shanghai Blue Design Industrial Design Co Ltd

14:40 - 15:10

**演讲题目：时尚引领·数字赋能的纺织品创新设计**

**内容摘要：**分析数字经济背景下纺织产业的发展机会，结合案例讲解纺织品创新设计的理论和方法。

**演讲嘉宾：**周赳，浙江理工大学纺织品设计研究所所长、教授、博导

**Speech Topic: Fashion Leadership - Digital-enabled Innovative Textile Design**

**Abstract:** The speech will analyze the development opportunities of the textile industry in the context of the digital economy and explain the theory and methodology of innovative textile design with case studies.

**Speaker:** Zhou Jiu, Professor, PhD supervisor, Director of the Institute of Textile Design, Zhejiang Sci-Tech University

15:10 - 15:40

**演讲题目：设计驱动力：塑造新时代企业与产品**

**内容摘要：**重点介绍工业设计如何助力企业产业升级与产品开发，探讨工业设计在企业创新中的关键作用，如何提升产品竞争力，以及如何在新消费市场中突出重围。

**演讲嘉宾：**韩颖，国家级工业设计中心·愉悦家纺有限公司设计总监

**Speech Topic: Driving Force of Design: Shaping Enterprises and Products in the New Era**

**Abstract:** The speech introduces how industrial design can help enterprises in industrial upgrading and product development, discussing the key role of industrial design in enterprise innovation, how to enhance product competitiveness, and how to stand out in the new consumer market.

**Speaker:** Han Ying, Design Director, Yuyue Home Textile Co Ltd (National Industrial Design Center)

15:40 - 16:10

**演讲题目：2024 中国纺织行业工业设计中心培育与评定工作推介**

**内容摘要：**针对中国纺织行业工业设计中心培育与评定工作，从评定管理办法、申报须知、申报条件与认定体系等方面进行精准讲解。

**演讲嘉宾：**祝丽娟，中国纺织信息中心流行趋势部副主任

**Speech Topic: Cultivation and Evaluation for 2024 China Textile Industrial Design Centers**

**Abstract:** The speech will cover the management measures for evaluating and developing textile industrial design centers in China, as well as the instructions for declaration, declaration conditions, and recognition systems.

**Speaker:** Zhu Lijuan, Deputy Director of Trend Department, China Textile Information Center

# 重点活动 – 市场信息及营销策略

## FEATURED EVENTS – MARKET INFORMATION & BUSINESS STRATEGIES

2024 纺织产业数字化应用趋势论坛  
2024 Textile Industry Digital Application Forum

论坛  
FORUM



2024 纺织产业数字化应用趋势论坛议题依旧将紧跟纺织服装产业数字化创新应用趋势，聚焦于纺服数字化研发设计、智慧生产和制造、数字营销等核心环节展开系列案例分享和数字化升级变革的话题讨论。

2024 Textile Industry Digital Application Trend Forum will focus on textile and clothing R&D and design, smart production and manufacturing, and digital marketing. There will be a series of case sharing and topic discussions on digital transformation.

### 2024.3.7

时间 Time	议程 Schedule	讲者 Speaker
14:30 – 14:35	开幕辞 Opening Speech	余诗慧，法兰克福展览（香港）有限公司总经理 Wilmet Shea, General Manager, Messe Frankfurt (HK) Ltd
14:35 – 14:55	纺织碳图谱 Textile Carbon Atlas	鲍劲松，东华大学机械工程学院智能制造研究所教授、博导、智能制造研究所所长 Jinsong Bao, Professor, Ph.D. Advisor, Director, Institute for Intelligent Manufacturing Department of Mechanical Engineering, Donghua University
14:55 – 15:15	服装纺织企业如何进行高效的色彩管理 How to Perform Efficient Colour Management	黄艳，COLORO 色彩专家，Coloro Intelligence 创意与研发总监 Huangyan, Color Expert, COLORO, Creative and R&D Director, Coloro Intelligence
15:15 – 15:35	数智赋能 – 激活纺织新引擎 Digital Intelligence Empowerment - Activating a New Textile Engine	刘红伟，杭州天富德泰信息技术有限公司 COO Hongwei Liu, COO, Hangzhou Tianfu Detai Information Technology Co Ltd
15:35 – 15:55	天丝™ 品牌的营销数字化 TENDEL™ Digital Marketing	李琦，兰精纤维（上海）有限公司纺织事业部中国区市场推广及品牌营销负责人 Maggie Li, Head of Marketing and Branding, Textile China, Lenzing Fiber (Shanghai) Co Ltd



15:55 – 16:10	数字化助力纺织服装跨境出海 Digitalization Helps Textile and Garment Industry Go Global	杨熙哲, 锦贯展览(厦门)有限公司联合创始人 Xizhe Yang, Co-founder, Jinguan Exhibition (Xiamen) Co Ltd
16:10 – 16:30	圆桌论坛 Panel Discussion	<p><b>主持人:</b> 汪琴丽, a&amp;s 传媒主编</p> <p><b>嘉宾:</b> 鲍劲松, 东华大学机械工程学院智能制造研究所教授、博导、智能制造研究所所长 刘红伟, 杭州天富德泰信息技术有限公司 COO 李琦, 兰精纤维(上海)有限公司纺织事业部中国区市场推广及品牌营销负责人</p> <p><b>Moderator:</b> Amy Wang, Editor in Chief, a&amp;s Media Group</p> <p><b>Panelists:</b> Jinsong Bao, Professor, Ph.D. Advisor, Director, Institute for Intelligent Manufacturing Department of Mechanical Engineering, Donghua University Hongwei Liu, COO, Hangzhou Tianfu Detai Information Technology Co Ltd Maggie Li, Head of Marketing and Branding, Textile China, Lenzing Fiber (Shanghai) Co Ltd</p>

\* 提供普通话 ↔ 英语同声传译

\* Mandarin Chinese ↔ English Simultaneous Interpretation will be provided

## 重点活动 – 技术

### FEATURED EVENTS – TECHNOLOGY AND SOLUTION

科创未来：新技术 新动能 新业态  
Future Based on Science and Innovation:  
New Technologies, New Impetus,  
New Business Formats

论坛  
FORUM



当前世界百年变局加速演进，国际格局深刻调整，区域自贸、贸易摩擦等因素对国际纺织产业链、供应链布局影响加深。而在向强国目标迈进的过程中，就纺织服装行业来说，短板技术及应用突破，大宗原料稳定安全供给、产业布局稳妥有序等关键问题的优化是纺织产业未来的使命任务。产品的研发与应用，人工智能的前沿技术创新及多技术领域的跨界融合，都将会造成一连串的多米诺效应，涌现出新技术、新动能、新成果、新趋势、新业态... 伴随着纺织产业边界的不断拓展以及外部经济赋能的不断深入，智能化、数字化将产业供给质量与效率带进了新高度。同时纤维新材料、精益加工设备、生态印染技术等科技创新成果支撑下的新模式、新业态不断呈现。科技创新力是产品的第一生命力，我们该如何用科技创新与技术应用为产业供给质量与效率注入新活力？如何将前沿技术落地为先进生产力，将科技创新与商业价值进行最大转化？将科技战略支撑与市场循环升级打造出产业前瞻性、引领性、原创性应用生态。实现纺织高质量发展的新跨越，在未来发展和国际竞争中赢得战略主动，一同共创智能化、绿色化、高端化的产业未来。

In today's world, where the international landscape is changing on a scale not seen in a century, regional free trade and international trade frictions are on the rise, severely impacting the industrial and supply chains of the global textile industry. To build China's strength in the textile industry, it is important to achieve breakthroughs in weak technologies and applications, ensure a steady and secure supply of bulk raw materials, and maintain a stable and sound industrial layout. The R&D and application of products, the innovations in AI and other cutting-edge technologies, as well as the integration of various technological fields will create a domino effect and bring forth new technologies, new impetus, new achievements, new trends, new formats... With the continuous expansion of boundaries and empowerment of external economy, the textile industry is becoming more intelligent and digitalized, bringing the industrial supply quality and efficiency to new levels. At the same time, new models and business formats are constantly emerging, supported by new fiber materials, lean processing equipment, ecological printing and dyeing technology and other innovative technologies. Scientific and technological innovation is vital to products, but how can it inject new vitality into the textile industry to improve its quality and efficiency? How should cutting-edge technologies be translated into advanced productivity to maximize the commercial value of technical innovation? It is imperative to promote a forward-looking, leading and original industrial ecology through technical strategies and market upgrading, so as to make a giant leap in the development of an intelligent, green and high-end textile industry that maintains the strategic initiative in future development and international competition.

2024.3.7

时间 Time	主题 Topic	讲者 Speakers
13:30 - 13:35	主持嘉宾开场 Opening remarks by the guest host	王军，中国服装论坛执行主席 Wang Jun, Executive Chairman of China Fashion Forum



6.1-J104  
热点交流  
Talking Point

6.1

地点 Venue

13:35 - 14:05	<p>开场致辞 Opening speech</p>	<p>徐迎新, 中国纺织工业联合会副会长 中国国际贸易促进委员会纺织行业分会会长 胡松, 中国纺织信息中心主任 温婷, 法兰克福展览(香港)有限公司董事总经理 Xu Yingxin, Vice President of China National Textile and Apparel Council (CNTAC) President of the Sub-Council of Textile Industry of China Council for the Promotion of International Trade (CCPIT TEX) Hu Song, Director of China Textile Information Center (CTIC) Wendy Wen, Managing Director of Messe Frankfurt (HK) Ltd</p>
14:05 - 15:45	<p>热点研判 Hotspot explorations</p>	<p>沈建峰, 猫人集团美力城时尚服饰事业部总经理 刘昊海, 探路者控股集团股份有限公司技术项目部负责人 王詠, TAGX 探观创始人 张寿荣, 德州华源生态科技有限公司市场部总监 雷铠鸿, 福建宇邦纺织科技有限公司上海创研中心总监 Shen Jianfeng, General Manager of Merrycheng Fashionable Apparel Division, Miiow Group Liu Haohai, Director of Toread Technology Project Department Wang Yong, Founder of TAGX Layne Zhang, Marketing Director of Dezhou Huayuan Ecotechnology Co Ltd A fabric enterprise (a leader in functional fabrics) Chris Lei, Director of Innovation Center Shanghai Fujian Unitex Technology Co Ltd</p>
15:45 - 16:20	<p>先锋对话 科技创新与商业价值 转化 Panel discussion Technological innovation and commercial value transformation</p>	<p><b>对话嘉宾:</b> - 田友如, 三六一度服装材料技术中心总监 - 黄俊勋, TRICKCOO 品牌主理人 / 上海岂可服饰有限公司 CEO - 金禄凯, eVent 中国区总经理, Ozarkgear 奥索卡董事 - 周龙, 风谜 FOOXMET 联合创始人 - 钟斌, 浙江嘉名染整有限公司纺织事业部执行副总经理 - 王永东, 上海德福伦新材料科技有限公司产品总监兼产品应用开发中心总经理 <b>Panelists:</b> - Tian Youru, Director of 361° Apparel Technical Center - Huang Junxun, Brand Manager of TRICKCOO / CEO of Shanghai TRICKCOO Fashion Co Ltd - Jin Lukai, General Manager of eVent China / Director of Ozarkgear - Zhou Long, Co-founder of FOOXMET - Zhong Bin, Executive Vice General Manager of Textile Business Unit of Zhejiang Charming Dyeing &amp; Finishing Co Ltd - Wang Yongdong, Product Director and General Manager of Product Application Development Center Shanghai Different Advanced Material Co Ltd</p>
16:20 - 16:50	<p>纺织风向标 Textile barometer</p>	<p>观点发布一: 应用技术装备与数字化制造的提升满足消费者需求下的新消费场景 发布嘉宾: 李强, 波司登集团首席信息官 观点发布二: 新型纺纱技术开发与市场应用的新场景 发布嘉宾: 董平, 华孚时尚股份有限公司总裁助理兼产业运营公司总经理 观点发布三: 消费需求精细化语境下让数智创新精准赋能纺织制造 发布嘉宾: 桂益龙, 卓尚服饰集团数字化总监 Opinion 1: New consumption scenarios with upgraded technological equipment and digital manufacturing to meet consumer demands Releaser: Li Qiang, Chief Information Officer of Bosideng Opinion 2: New fiber and yarns technology development and market application scenarios Releaser: Dong Ping, Assistant President of Huafu Fashion Co Ltd and General Manager of Industrial Operation Company Opinion 3: Digital technology innovation precisely empowers textile manufacturing in the context of refined consumer demand Releaser: Gui Yilong, CIO of Excellent Fashion Garment</p>

## 重点活动 – 可持续发展议题

### FEATURED EVENTS – SUSTAINABILITY ISSUE

纺织创新之路：展示纺织品回收的未来  
Threads of Innovation:  
Unveiling the Future of Textile Recycling

论坛  
FORUM

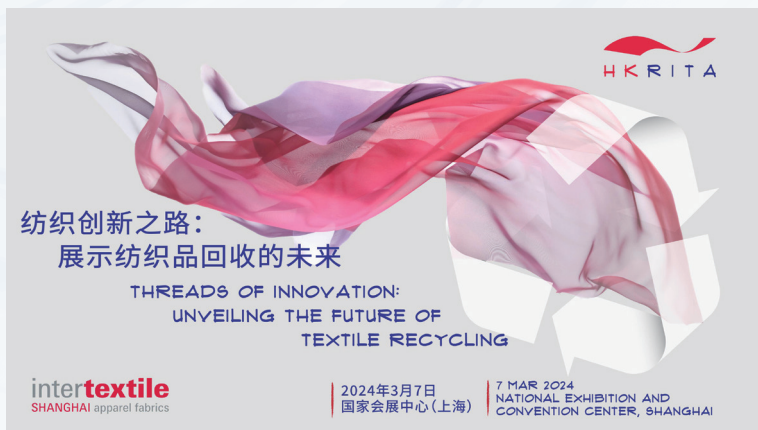

准备迎接纺织品回收的未来吗？欢迎参加 HKRITA 主办的研讨会，《纺织创新之路：展示纺织品回收的未来》，我们将探讨行业发展的最新进展，探索正在重塑时尚格局的革命性技术和可持续实践，推动时尚产业迈向更环保和循环的转变。一起探索纺织市场上最热门的话题！

Ready to dive into the future of textile recycling? Join us for an engaging seminar, "Threads of Innovation: Unveiling the Future of Textile Recycling," where we explore the latest advancements shaping the industry. Discover revolutionary technologies and sustainable practices that are reshaping the fashion landscape. Be part of the conversation driving the shift towards a more eco-friendly and circular fashion industry. Don't miss out on this opportunity to explore the hottest topic in the market.

#### 2024.3.7

时间 Time	议程 Schedule	讲者 Speakers
11:00 - 11:40	个人演讲 Individual Presentation	陈煜明, 庆业集团高级技术经理 Kenneth Chan, Senior Technical Manager, Winnitex Group
		谢恺宜, 香港纺织及成衣研发中心高级经理, 研究和项目设计 Clara Tse, Senior Manager, Research Project Design, The Hong Kong Research Institute of Textiles and Apparel (HKRITA)
		王琳, 中国纺织工业联合会产业部资源循环与技术促进业务主任 Lin Wang, Project Director, Comprehensive Utilization of Resources, China National Textile and Apparel Council (CNTAC), Ministry of Information Industry
		杨新铭, 莱卡亚太技术总监 Jack Yang, Asia R&D Director, The LYCRA Company

地点 Venue



5.1-K48  
前沿分享  
Forum Space

5.1

11:40 - 12:20

圆桌论坛  
Panel Discussion

**主持人:**

叶晓薇, yehyehyeh 创新社创办人

**嘉宾:**

陈煜明, 庆业集团高级技术经理

谢恺宜, 香港纺织及成衣研发中心高级经理, 研究和项目设计

王琳, 中国纺织工业联合会产业部资源循环与技术促进业务主任

杨新铭, 莱卡亚太技术总监

**Moderator:**

Shaway Yeh, Founder, yehyehyeh

**Panelists:**

Kenneth Chan, Senior Technical Manager, Winnitex Group

Clara Tse, Senior Manager, Research Project Design, The Hong

Kong Research Institute of Textiles and Apparel (HKRITA)

Lin Wang, Project Director, Comprehensive Utilization of Resources,

China National Textile and Apparel Council (CNTAC), Ministry of

Information Industry

Jack Yang, Asia R&D Director, The LYCRA Company

12:20 - 12:30

问答环节  
Q&A

\* 提供普通话 ↔ 英语同声传译

\* Mandarin Chinese ↔ English Simultaneous Interpretation will be provided

## 重点活动 – 可持续发展议题

### FEATURED EVENTS – SUSTAINABILITY ISSUE

“可持续未来材料”探索与展望  
Future Materials: Sustainable Exploration  
and Prospect

论坛  
FORUM



为推动中国纺织工业未来材料的可持续探索、对话和应用，激发产业未来的可持续领导力，推动产业经济与社会高质量协调发展，中国纺织工业联合会社会责任推广委员会于 2021 年启动首期“可持续未来材料”开源项目，重点开展纺织可持续未来材料的探索性研究。2024 年 3 月，“可持续未来材料”研究成果将正式发布。

In order to promote the sustainable exploration, dialogue and application of future materials in China's textile industry, inspire the future sustainable leadership for the industry, and promote the high-quality coordinated development of the industry's economy and society, the Social Responsibility Construction Association of China National Textile and Apparel Council launched the first phase "Future Sustainable Materials" open-source project in 2021, which focuses on exploratory research into sustainable future materials for textiles. In March 2024, the research findings on "Future Sustainable Materials" will be officially released.

#### 2024.3.7

时间 Time	主题 Topic	讲者 Speakers
14:30 - 14:35	主持开场 Host Announces the Opening of the Forum	
14:35 - 14:40	开场致辞 Opening Speech	俞建勇，中国工程院院士、东华大学校长 Yu Jianyong, Academician of Chinese Academy of Engineering, President of Donghua University
14:40 - 14:45	开场致辞 Opening Speech	李陵申，中国纺织工业联合会副会长 Li Lingshen, Vice President, China National Textile and Apparel Council (CNTAC)
14:45 - 15:05	主题演讲 Keynote Speech	阎岩，中国纺织工业联合会副会长 Yan Yan, Vice President, China National Textile and Apparel Council (CNTAC)
15:05 - 15:25	主题演讲 Keynote Speech	Florian Heubrandner，兰精集团执行副总裁 Florian Heubrandner, Executive Vice President, Lenzing Group



地点 Venue



5.1-K48  
前沿分享  
Forum Space

5.1

15:25 - 15:45	主题演讲 Keynote Speech	鲁晓朝, 伊士曼 (中国) 投资管理有限公司 纺织事业部亚太商务总监 Edmund Lu, Commercial Director AP, Textile, Eastman Chemical (China) Co Ltd
15:45 - 16:05	主题演讲 Keynote Speech	王华平, 东华大学材料学院常务副院长 Wang Huaping, Executive Vice Dean, School of Materials, Donghua University
16:05 - 17:00	论坛 可持续未来材料展望 Panel Materials for a Sustainable Future	蔡君珊, WGSN 消费者趋势总监 材料端企业代表 品牌端企业代表 行业专家 Sara Cai, Insight Director of WGSN Representatives from textile material companies Representatives from brand companies Industry expert

\* 提供普通话 ↔ 英语同声传译

\* Mandarin Chinese ↔ English Simultaneous Interpretation will be provided

# 活动总览 – 流行趋势

## EVENT SCHEDULE – DESIGN AND TREND

**2024.3.6**

时间 Time 地点 Venue	主题 Topic	讲者 Speakers	语言 Language
10:40 - 11:30 5.1-K149	<b>研讨会 Seminar</b> Intertextile 2025 春夏流行趋势解析 Intertextile Trends Spring/Summer 2025	Kai Chow, DONEGER   TOBE 创作总监 Kai Chow, Creative Director, DONEGER   TOBE	英语 * English*
11:35 - 12:15 5.1-K149	<b>研讨会 Seminar</b> 25 春夏全球趋势色彩 Global Key Colour S/S 25	王鲁源, 上海元彩科技有限公司色彩专家 Lulu Wang, Colorist, COLORO	普通话 * Mandarin*
12:20 - 13:00 5.1-K149	<b>研讨会 Seminar</b> WGSN 2025 春夏面料趋势 WGSN Textiles Forecast S/S 25	岳文, WGSN 趋势顾问 Wen Yue, Trend Consultant, WGSN	普通话 * Mandarin*
14:00 - 14:40 5.1-K149	<b>研讨会 Seminar</b> 2025 春夏中国纺织面料流行趋势 ——生活方式 2025SS Fabrics China Trend - Lifestyle	渠梦玮, 中国纺织信息中心流行趋势部趋势研究员 / FASHION INSIGHT 编辑 Mengwei Qu, Trend Researcher of Trends Department, China Textile Information Center / Editor of FASHION INSIGHT	普通话 Mandarin
14:40 - 15:10 5.1-K149	<b>研讨会 Seminar</b> 2025 春夏中国艺术染整流行趋势 2025SS Chinese Dyeing & Finishing Trend	中国纺联艺术染整与现代扎染流行趋势研究中心 罗竞杰, 东华大学服装与艺术设计学院服装与服饰 专业负责人 东华·江苏华艺艺术染整科技创新研究中心主任 Fabrics China Trend Research Center - Artistic Dyeing & Finishing and Modern Tie Dyeing Jingjie Luo, Director of Apparel & Accessories Department, College of Fashion and Design of Donghua University Director of Donghua · Jiangsu Huayi Artistic Dyeing & Finishing Innovation Research Center	普通话 Mandarin
15:10 - 15:40 5.1-K149	<b>研讨会 Seminar</b> 新技术、新材料、新价值——解读 2025 春夏流行纱线新趋势 New Technology, New Materials, New Value - Interpreting the New Trend of Popular Yarns in 2025SS	中国纺联纺织新材料纱线流行趋势研究中心 朱培, 山东联润新材料科技有限公司总经理助理 Fabrics China Trend Research Center - New Fiber-based Yarn Pei Zhu, General Manager Assistant, Shandong Long Run Textile Co Ltd	普通话 Mandarin
15:40 - 16:10 5.1-K149	<b>研讨会 Seminar</b> 2025 春夏精毛纺女装面料流行趋势 2025SS Fashion Trend of Worsted Textiles for Womenswear	中国纺联女装精毛纺面料流行趋势研究中心 李雅, 江苏丹毛纺织股份有限公司面料设计师 Fabrics China Trend Research Center - Worsted Textiles for Womenswear Ya Li, Textiles Designer, Jiangsu Danmao Textile Co Ltd	普通话 Mandarin
16:00 - 16:30 5.1-K149	<b>研讨会 Seminar</b> 洛杉矶春夏牛仔市场及趋势更新 Los Angeles Market and Trend Update for Denim in Spring / Summer	Bryan Hoyos, 广东前进牛仔布有限公司美国市场 总监 Bryan Hoyos, USA Marketing Director, Advance Denim Co Ltd	英语 * English*

\* 提供普通话 ↔ 英语同声传译

\* Mandarin Chinese ↔ English Simultaneous Interpretation will be provided

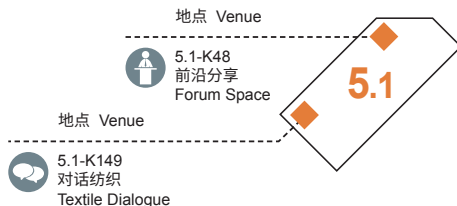

## 2024.3.7

时间 Time 地点 Venue	主题 Topic	讲者 Speakers	语言 Language
10:20 - 11:00 5.1-K149	<b>研讨会 Seminar</b> 2025 春夏中国纺织面料流行趋势——色彩解析 2025SS Fabrics China Trend - Color Trend	王玢, 中国纺织信息中心流行趋势部趋势研究员 / FASHION INSIGHT 编辑 Bin Wang, Trend Researcher of Trends Department, China Textile Information Center / Editor of FASHION INSIGHT	普通话 Mandarin
11:00 - 11:30 5.1-K149	<b>研讨会 Seminar</b> 2025 春夏图案趋势分析 2025SS Pattern Trend Analysis	洪溶, 中国纺织信息中心时尚智能部运营经理 Rong Hong, Operations Manager of Fashion Intelligence Department, China Textile Information Center	普通话 Mandarin
11:30 - 12:00 5.1-K149	<b>研讨会 Seminar</b> 环保纱线助力健康生活 Eco-friendly Yarn - A Way to Achieve a Healthy Life	中国纺联差别化功能性色纺纱流行趋势研究中心 张淑云, 德州华源集团有限公司配色室主管 Fabrics China Trend Research Center - Functional Colored Spun Yarn Shuyun Zhang, Color Design Director, Dezhou Huayuan Group Co Ltd	普通话 Mandarin
12:00 - 12:30 5.1-K149	<b>研讨会 Seminar</b> 针仿梭不是仿, 而是面料的新物种 Woven-look Knitting, not Merely an Adoption, but an Evolution	中国纺联针织牛仔流行趋势研究中心 秦刚, 恒亮纺织有限公司营销总监 Vincent Qin, Marketing Director, Hengliang Textile Co Ltd	普通话 Mandarin
12:30 - 12:50 5.1-K149	<b>研讨会 Seminar</b> 绿色纤维莱赛尔的应用趋势 Market Application of Lyocell - the New Generation of Green Technology Fiber	王本行, 赛得利集团华东销售经理 Benhang Wang, Sales Manager, Sateri Lyocell	普通话 Mandarin
12:55 - 13:45 5.1-K149	<b>研讨会 Seminar</b> SS25 Women's Fashion Trend Forecast 25 春夏女装趋势讲解	Benedicte Peaudecerf, PeclersParis 风格与趋势研究设计师 Benedicte Peaudecerf, Style Designer and Trend Forecaster, PeclersParis	英语 / 普通话 English/ Mandarin

## 2024.3.8

时间 Time 地点 Venue	主题 Topic	讲者 Speakers	语言 Language
10:30 - 11:00 5.1-K48	<b>产品发布会 Production Presentation</b> 面向 24-25 春夏的纺织面料介绍 Introduction of Textile Fabrics for 24-25 S/S	任越, 柴屋株式会社销售 Yue Ren, Sales, Shibaya Co Ltd	普通话 Mandarin
11:05 - 11:35 5.1-K48	<b>产品发布会 Production Presentation</b> 潮流面料 Trend Fabric	村田侑哉, 泷定大阪商贸(上海)有限公司销售经理 Yuya Murata, Sales Manager, Takisada - Osaka Trading (Shanghai) Co Ltd	普通话 Mandarin

\* 提供普通话 ↔ 英语同声传译

\* Mandarin Chinese ↔ English Simultaneous Interpretation will be provided

# 活动总览 – 市场信息及营销策略

## EVENTS SCHEDULE – MARKET INFORMATION & BUSINESS STRATEGIES

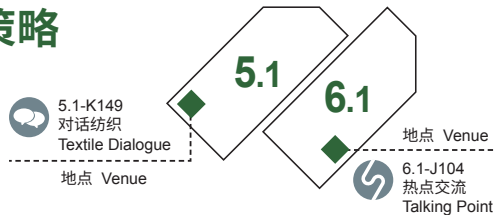

### 2024.3.6

时间 Time 地点 Venue	主题 Topic	讲者 Speakers	语言 Language
13:05 - 13:55 5.1-K149	<b>研讨会 Seminar</b> 天丝™—从 2B 品牌到 2B2C2me 品牌的发展之路 The Approach of TENCEL™ Brand from 2B to 2B2C2me	李琦, 兰精中国市场推广及品牌营销负责人 Julia Ulrich, 兰精集团全球产品管理负责人 Maggie Li, Head of Marketing & Branding, Lenzing Textile, China Julia Ulrich, Global Product Manager, Lenzing Group	普通话 / 英语 * Mandarin / English*
14:00 - 16:10 6.1-J104	<b>论坛 Forum</b> 2024 年第四届纺织工业设计创新论坛 2024 The Fourth Innovation Forum for Textile Industrial Design	第一部分: 论坛致辞 第二部分: 设计的价值 第三部分: 时尚引领·数字赋能的纺织品创新设计 第四部分: 设计驱动力: 塑造新时代企业与产品 第五部分: 2024 中国纺织行业工业设计中心培育与评定工作推介 Part 1: Forum Address Part 2: The Value of Design Part 3: Fashion Leadership - Digital-enabled Innovative Textile Design Part 4: Driving Force of Design: Shaping Enterprises and Products in the New Era Part 5: Cultivation and Evaluation for 2024 China Textile Industrial Design Centers	普通话 Mandarin

### 2024.3.7

时间 Time 地点 Venue	主题 Topic	讲者 Speakers	语言 Language
14:30 - 16:30 5.1-K149	<b>论坛 Forum</b> 2024 纺织产业数字化应用趋势论坛 2024 Textile Industry Digital Application Forum	第一部分: 开幕辞 第二部分: 纺织碳图谱 第三部分: 服装纺织企业如何进行高效的色彩管理 第四部分: 数智赋能—激活纺织新引擎 第五部分: 天丝™ 品牌的营销数字化 第六部分: 数字化助力纺织服装跨境出海 第七部分: 圆桌论坛 Part 1: Opening Speech Part 2: Textile Carbon Atlas Part 3: How to Perform Efficient Color Management Part 4: Digital Intelligence Empowerment - Activating a New Textile Engine Part 5: TENCEL™ Digital Marketing Part 6: Digitalization Helps Textile and Garment Industry Go Global Part 7: Panel Discussion	普通话 * Mandarin*

\* 提供普通话 ↔ 英语同声传译

\* Mandarin Chinese ↔ English Simultaneous Interpretation will be provided

# 活动总览 – 技术

## EVENTS SCHEDULE – TECHNOLOGY AND SOLUTION



6.1-J104  
热点交流  
Talking Point

6.1

地点 Venue

2024.3.6

时间 Time 地点 Venue	主题 Topic	讲者 Speakers	语言 Language
10:30 - 11:00 6.1-J104	<b>研讨会 Seminar</b> 户外冲锋衣材料设计及研发 Design and Development of Outdoor Assault Suit Materials	薛婷, 昆山东利新材料科技有限公司副总经理 Snow Xue, Deputy General Manager, Kunshan Doonly New Material Technology Co Ltd	普通话 Mandarin
11:05 - 11:35 6.1-J104	<b>研讨会 Seminar</b> 1. 2023 年羽绒检测大数据 2. 时尚亦可循环 1. Big Data of Down Testing of GTTC in 2023 2. Make Fashion Circular	张亮亮, 广州检验检测认证集团有限公司客服三部部长 毛凤伟, 浙江三星羽绒股份有限公司常务副总 Eric Zhang, Director of the Third Customer Service Department, Guangzhou Inspection Testing and Certification Group Co Ltd Feathe Mao, Deputy General Manager, Zhejiang Samsung Down Co Ltd	普通话 Mandarin
11:40 - 12:10 6.1-J104	<b>研讨会 Seminar</b> 技术迭代背景下, 纺织企业如何升级现有模式 How to Upgrade Existing Models in Textile Enterprises under the Background of Technological	李文其, 浙江凌迪数字科技有限公司中国区面料数字化专家 Tiki Li, Zhejiang Lingdi Digital Technology Co Ltd	普通话 Mandarin
12:15 - 12:45 6.1-J104	<b>研讨会 Seminar</b> 凯喜雅 “innosilk 洗可穿真丝技术” 应用分享 CATHAYA “innosilk Washable Wearable Silk Fabric” Technology Sharing	李鹏, 浙江凯喜雅国际股份有限公司国家级工业设计中心负责人 Peng Li, Manager of National-level Industrial Design Center, Zhejiang Cathaya International Co Ltd	普通话 Mandarin
13:10 - 13:40 6.1-J104	<b>研讨会 Seminar</b> 源木而生, 自然纤活 ——纤维素纤维的多场景应用分享 A Touch of Nature —— Multi-scenario Application Sharing of Viscose Fibre	颜荟, 赛得利集团优可丝® 市场经理 Effy Yan, Marketing Manager, Sateri Group	普通话 Mandarin

\* 提供普通话 ↔ 英语同声传译

\* Mandarin Chinese ↔ English Simultaneous Interpretation will be provided

# 活动总览 – 技术

## EVENTS SCHEDULE – TECHNOLOGY AND SOLUTION

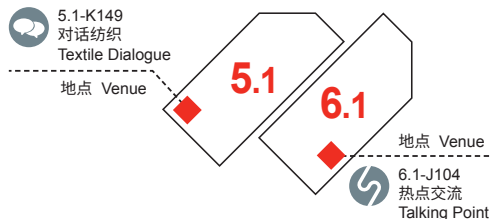

2024.3.7

时间 Time 地点 Venue	主题 Topic	讲者 Speakers	语言 Language
10:30 - 11:20 6.1-J104	<b>研讨会 Seminar</b> HeiQ Skin Care——注入益生菌的长效 美肤纺织品整理技术 HeiQ Skin Care - Boost the Skin Natural Microbiome	刘敬萍, HeiQ 瑞士海屹科中国区总经理 Robert Liu, General Manager, HeiQ Switzerland for China	普通话 Mandarin
11:30 - 12:20 6.1-J104	<b>研讨会 Seminar</b> 纺织新材料可持续解决方案: 伊士曼 Naia™ Renew 醋酸纤维——特点、应 用、价值优势 Eastman Naia™ Renew Cellulosic Fiber - A Sustainable Solution to Textile Industry	高建平, 伊士曼亚太区应用开发技术经理 Robert Gao, Group Leader, Asia-Pacific AD/TS, Textile, Eastman Chemical Company	普通话* Mandarin*
13:30 - 16:50 6.1-J104	<b>论坛 Forum</b> Intertextile FORUM 纺织论坛	第一部分: 主持嘉宾开场 第二部分: 开场致辞 第三部分: 热点研判 第四部分: 先锋对话 第五部分: 纺织风向标 Part 1: Opening Remarks by the Guest Host Part 2: Opening Speech Part 3: Hotspot Explorations Part 4: Panel Discussion Part 5: Textile Barometer	普通话 Mandarin
13:50 - 14:20 5.1-K149	<b>研讨会 Seminar</b> 面料舒适度趋势分析及面料手感研究报 告——PRUTAC® Fabric Comfort Trend Analysis and Fabric Feel Study - PRUTAC®	朱林, 浙江嘉华特种尼龙有限公司运营事业部营销 总监兼品牌总监 Duncan Zhu, Marketing Director and Brand Director of Operations Division, Prutex Nylon Co Ltd	普通话 Mandarin

\* 提供普通话 ↔ 英语同声传译

\* Mandarin Chinese ↔ English Simultaneous Interpretation will be provided

# 活动总览 – 可持续发展议题

## EVENTS SCHEDULE – SUSTAINABILITY ISSUE

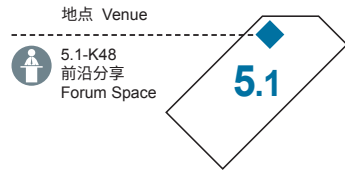

2024.3.6			
时间 Time 地点 Venue	主题 Topic	讲者 Speakers	语言 Language
10:10 - 10:40 5.1-K48	<b>研讨会 Seminar</b> 印染企业化学品管理及可持续发展浅析 纺织供应链可持续发展——TE 项目及碳足迹核算 Briefing Chemical Management and Sustainability Development of Dyeing and Finishing Company The Textile Supply Chain Sustainable Development - TE Project and Carbon Footprint Calculation	胡年睿, Intertek 天祥纺织及鞋类事业部技术经理 仇彬鸿, Intertek 高级经理 Nina Hu, Technical Manager, Intertek China Softlines Joyce Qiu, Senior Manager, Intertek	普通话 * Mandarin*
11:00 - 11:30 5.1-K48	<b>研讨会 Seminar</b> 全球有机纺织品标准 (GOTS) ——从农田种植到终端产品的整体可持续发展解决方案 GOTS: A Holistic Solution to Sustainability from Field to Fashion	时怡, 全球有机纺织品标准 (GOTS) 亚太区代表人 Felicia Shi, Representative in APAC, Global Organic Textile Standard (GOTS)	普通话 * Mandarin*
11:40 - 12:10 5.1-K48	<b>研讨会 Seminar</b> 合成纤维: 可持续性和性能 Synthetic Fibers: Sustainability & Performance	Ben Sainsbury, 杭州爱达福乐检测技术有限公司中国区运营及检测总经理 Ben Sainsbury, General Manager, Testing & Operations, IDFL China	英语 * English*
12:15 - 12:45 5.1-K48	<b>研讨会 Seminar</b> OEKO-TEX® 2024 新规变化与纺织品有害物质检测 OEKO-TEX® New Regulations 2024 Changes and Detection of Harmful Substances in Textiles	聂辰, 海恩斯坦纺织检验 (上海) 有限公司业务总监 Charles Nie, Business Director, Hohenstein Textile Testing (Shanghai) Co Ltd	普通话 * Mandarin*
12:50 - 13:50 5.1-K48	<b>研讨会 Seminar</b> 抖 in 宝藏衣橱 春夏新趋发布 Douyin Wardrobe - New Trends for Spring & Summer Selections	许小娇, 抖音电商综合业务女装行业运营总监 Xiaojiao Xu, Operations Director, Women's Apparel, Douyin E-Commerce	普通话 Mandarin
14:00 - 14:30 5.1-K48	<b>研讨会 Seminar</b> 在中国开创可持续时尚的挑战 Challenge Pioneering Sustainable Fashion in China	Xenia Sidorenko, UseDem 创始人 Xenia Sidorenko, Founder, UseDem	英语 * English*
14:35 - 15:05 5.1-K48	<b>研讨会 Seminar</b> 法兰克福展览集团的 Texpertise Economy 标准体系   商业与可持续发展的完美结合 Texpertise Economy by Messe Frankfurt   Where business meets sustainability	Claudia Franz, 法兰克福展览集团家用及装饰纺织品、服装面料及时装品牌管理总监 Claudia Franz, Director Brand Management Interior & Contract Textiles/Apparel Fabrics and Fashion, Messe Frankfurt Exhibition GmbH	英语 * English*
15:10 - 15:40 5.1-K48	<b>研讨会 Seminar</b> OEKO-TEX® 2024 新规助力企业可持续发展之路 New OEKO-TEX® 2024 Regulation Helps Companies on the Road to Sustainability	施剑, TESTEX 上海业务经理 James Shi, Senior Supervisor, Customer Service, TESTEX Shanghai	普通话 * Mandarin*
15:45 - 16:15 5.1-K48	<b>研讨会 Seminar</b> 品质支援服务 Quality Support Service	李艳, 上海爱丽纺织技术检验有限公司试验室主管 Yan Li, Shanghai Aili Boken Quality Evaluation Co Ltd	普通话 * Mandarin*

\* 提供普通话 ↔ 英语同声传译

\* Mandarin Chinese ↔ English Simultaneous Interpretation will be provided

# 活动总览 – 可持续发展议题

## EVENTS SCHEDULE – SUSTAINABILITY ISSUE

地点 Venue



5.1-K48  
前沿分享  
Forum Space

5.1

### 2024.3.7

时间 Time 地点 Venue	主题 Topic	讲者 Speakers	语言 Language
10:15 - 10:45 5.1-K48	<b>研讨会 Seminar</b> 在色彩中看见中国：以丝绸为载体，重建中国色彩话语权 Recognize China in Color: Rebuild Chinese Color Discourse Power with Silk	王鹏铖，浙江凯喜雅时迈服饰科技有限公司总经理 Pengcheng Wang, President, Zhejiang Cathaya Shimai Cloth & Technology Co Ltd	普通话 Mandarin
11:00 - 12:30 5.1-K48	<b>论坛 Forum</b> 纺织创新之路：展示纺织品回收的未来 Threads of Innovation: Unveiling the Future of Textile Recycling	叶晓薇，yehyehyeh 创新社创办人 陈焯明，庆业集团高级技术经理 谢恺宜，香港纺织及成衣研发中心高级经理，研究和项目设计 王琳，中国纺织工业联合会产业部资源循环与技术促进业务主任 杨新铭，莱卡亚太技术总监 Shaway Yeh, Founder, yehyehyeh Kenneth Chan, Senior Technical Manager, Winnitex Group Clara Tse, Senior Manager, Research Project Design, The Hong Kong Research Institute of Textiles and Apparel (HKRITA) Lin Wang, Project Director, Comprehensive Utilization of Resources, China National Textile and Apparel Council (CNTAC), Ministry of Information Industry Jack Yang, Asia R&D Director, The LYCRA Company	普通话* Mandarin*
12:40 - 13:10 5.1-K48	<b>研讨会 Seminar</b> 绿色纺织产品评价与认证 Green Textile Product Assessment and Certification	刘明，中纺标检验认证股份有限公司认证事业部主任 Ming Liu, Director of Certification Department, Chinatesta Textile Testing & Certification Services	普通话 Mandarin
13:15 - 13:45 5.1-K48	<b>研讨会 Seminar</b> 可持续未来：再生农业标准与塑料回收标准 Sustainable Futures: Standards for Regenerative Agriculture and Plastic Recycle	张韬，世优认证（上海）有限公司技术部经理 Tao Zhang, Technical Manager, Control Union Certification (Shanghai) Co Ltd	普通话* Mandarin*
13:50 - 14:20 5.1-K48	<b>研讨会 Seminar</b> 绿色低碳供应链助力纺织行业可循环生态发展 Green and Low Carbon Supply Chain Accelerate the Circular Development of Textile Industry	朱青，SGS 通标标准技术服务有限公司高级项目经理 Nicole Zhu, Senior Project Manager, SGS-CSTC Standards Technical Services Co Ltd	普通话* Mandarin*
14:30 - 17:00 5.1-K48	<b>论坛 Forum</b> “可持续未来材料”探索与展望 Future Materials: Sustainable Exploration and Prospect	第一部分：开场致辞 第二部分：主题演讲 第三部分：论坛 Part 1: Opening Speech Part 2: Keynote Speech Part 3: Panel	普通话* Mandarin*

### 2024.3.8

时间 Time 地点 Venue	主题 Topic	讲者 Speakers	语言 Language
11:40 - 12:10 5.1-K48	<b>产品发布会 Production Presentation</b> 引领循环可持续：OEKO-TEX® 和 ZDHC 铺前进步之路 Navigating Sustainable Circularity: OEKO-TEX® and ZDHC Paving the Path Forward	魏琳达，TESTEX AG 集团首席商务官 Linda Wegelin, Group Chief Commercial Officer, TESTEX AG	英语 English

\* 提供普通话 ↔ 英语同声传译

\* Mandarin Chinese ↔ English Simultaneous Interpretation will be provided



# yarnexpo

中国国际纺织纱线(春夏)展览会  
China International Trade Fair for Fibres and Yarns

2024.3.6 – 8

8.2<sub>Hall</sub> 馆

国家会展中心 (上海)

Hall 8.2, National Exhibition and  
Convention Center (Shanghai), China

## 同期活动

Fringe Programme



 messe frankfurt



研讨会日程  
Seminar schedule

## 同期活动场地

## Fringe Programme Venues

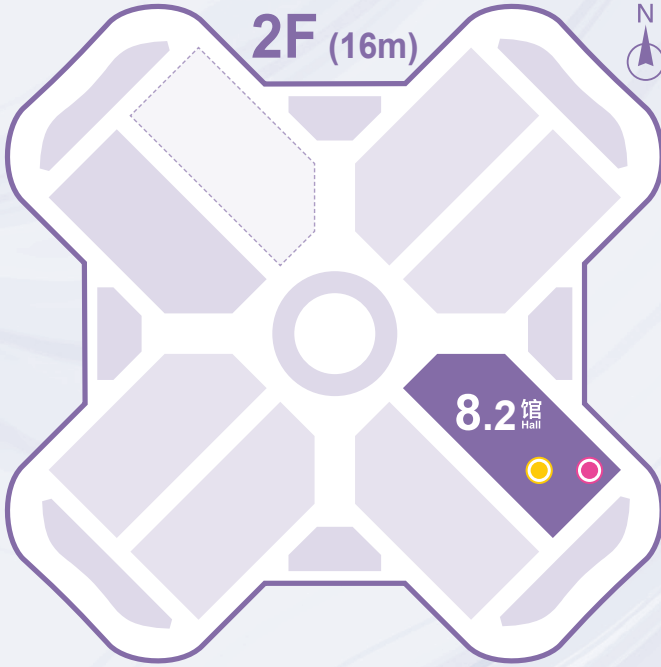

-  中国纤维流行趋势发布秀场  
纺织材料创新论坛  
China Fibers Fashion Trends  
Textile Materials Innovation Forum
-  中国纤维流行趋势  
中国纱线流行趋势  
China Fibers Fashion Trends  
China Yarns Fashion Trends

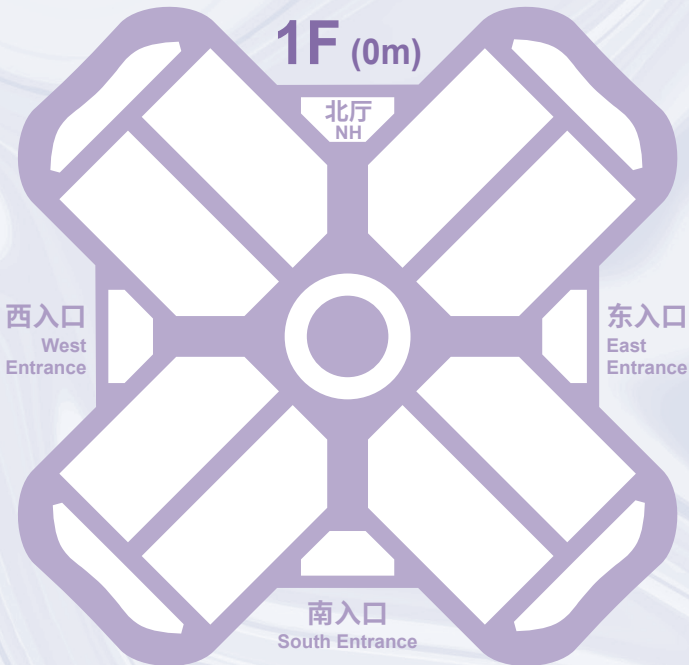

# 中国纤维流行趋势发布会 及企业产品发布会

## China Fibers Fashion Trends and Enterprise Product Launch



2024.3.6		
时间 Time	活动主题 Content	发布单位 Company
10:30 - 11:50 ● 8.2-H128	桐昆·中国纤维流行趋势 2024/2025 发布会 Tongkun · China Fibers Fashion Trends 2024/2025 Show	中国化学纤维工业协会 China Chemical Fibers Association 东华大学 Donghua University 中国棉纺织行业协会 China Cotton Textile Association
11:50 - 12:25 ● 8.2-H128	中国纤维流行趋势 2024/2025 深度解读 Interpretion of China Fibers Fashion Trends 2024/2025	王华平, 东华大学材料科学与工程学院 Mr Wang Huaping, College of Materials Science and Engineering, DHU
12:25 - 12:45 ● 8.2-H128	中国纤维流行趋势 2024/2025 ——纤·多元探索入选纤维应用趋势发布 China Fibers Fashion Trends 2024/2025 - Selected Fiber Application Trends of Fiber · Diversified Explorations	时尚趋势咨询机构 POP·趋势 Fashion Trend Consulting Agency 流行趋势研究与推广工作室 Fashion Trend Research and Promotion Studio
13:00 - 13:40 ● 8.2-H128	源·莱——2024 莱赛尔纤维应用趋势发布秀 Origin · Green - 2024 Lyocell Application Trends Launch	中国化学纤维工业协会莱赛尔纤维分会 China Chemical Fibers Association Lyocell Branch
14:00 - 14:40 ● 8.2-H128	何以为“纤” ——通用技术中纺绿纤莱赛尔产品发布秀 What Can Be In The Lead - GENERTEC G-FIBER Lyocell Products Launch	中纺院绿色纤维股份公司 CHINA TEXTILE ACADEMY GREEN FIBRE CO LTD
15:00 - 15:40 ● 8.2-H128	莱赛尔涡流纺时尚发布盛典 Lyocell MVS Fashion Release Ceremony	赛得利集团 Sateri Group 苏州京奕纺织进出口有限公司 Suzhou Jingyi Textile Import and Export Co Ltd
16:00 - 16:40 ● 8.2-H128	“织·实”中国石化高端纤维产品推介会 "Weaving and Realizing" China Petrochemical Premium Fiber Product Promotion Conference	中国石油化工集团有限公司 China Petrochemical Corporation
2024.3.7		
10:00 - 11:10 ● 8.2-H128	2024/2025 白鲨·中国纱线流行趋势 2024/2025 White Shark·China Yarns Fashion Trends	中国棉纺织行业协会 China Cotton Textile Association
11:30 - 12:10 ● 8.2-H128	华峰千禧·中国纤维品牌联动创享汇特别活 动——中国纤维品牌评价指标体系宣贯 Huafon QIANXI · China Fibers Co- branding World Special Forum - Promotion of "Indicator System for the Evaluation of Chinese Fiber Brand"	中国化学纤维工业协会 China Chemical Fibers Association 华峰化学股份有限公司 Huafon Chemical Co Ltd 江南大学 Jiangnan University 中国纺织工业联合会品牌工作办公室 Brand Office of China National Textile & Apparel Council
13:00 - 13:40 ● 8.2-H128	冷暖新科技, 健康再升级 ——太极石纤维产品发布会 Fibers Product Release Conference from Taichistone - New Technology for Cooling, Warming and Healthing	太极石股份有限公司 Tai Chi Stone Co Ltd
14:00 - 14:40 ● 8.2-H128	吉林化纤集团可持续人造丝产品发布会 Jilin Chemical Fiber Group Sustainable Rayon Product Launch	吉林化纤集团有限责任公司 Jilin Chemical Fiber Group Co Ltd
15:00 - 15:40 ● 8.2-H128	军民两用纤维产业链论坛暨目录发布会 Civil-military Dual-use Fiber Industry Chain Forum and Directory Release Conference	中国化学纤维工业协会 China Chemical Fibers Association 新兴际华(北京)材料技术研究院有限公司 Xinxing Jihua (Beijing) Material Technology Research Institute Co Ltd

# 纺织材料创新论坛

## ——中国纤维流行趋势专场

### Textile Materials Innovation Forum - China Fibers Fashion Trends Forum

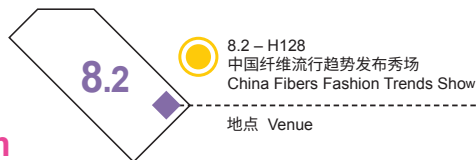

2024.3.7

主题：报告  
Topic: Report

时间 Time	活动主题 Content	发布单位 Company
16:00 - 16:15 8.2-H128	异形双组分涤纶复合纤维的研发与应用 Development and Application of Special-shaped Two-component Polyester-nylon Composite Fibers	王国柱, 桐昆集团股份有限公司 Wang Guozhu, Tongkun Group Co Ltd
16:15 - 16:30 8.2-H128	生物基尼龙 EYLON 伊纶材料在纺织应用中的市场前景和研发实践 Market Prospects and Research Practices of Bio-based Nylon EYLON® Material in Textile Applications	郑文昌, 黑龙江伊品新材料有限公司 Zheng Wenchang, Heilongjiang EPPEN New Material Co Ltd
16:30 - 16:45 8.2-H128	相变 (PCM) ——智能调温纤维的最新进展 Latest Progress of PCM - Intelligent Temperature Control Fiber	井志臣, 天津荣唐高性能纤维有限公司 Jing Zhichen, Tianjin Glory Tang Hi-Tech Fiber Co Ltd
16:45 - 17:00 8.2-H128	仿真差异化系列聚酯短纤维的开发和应用 Development and Application of Imitational Differentiated Polyester Stable Fiber	郝聃, 上海德福伦新材料科技有限公司 Hao Dan, Shanghai Different Advanced Material Co Ltd
17:00 - 17:15 8.2-H128	“绿”动奥神, “碳”路未来——奥神可持续产品开发现状 Green-oriented - Development Status of Aoshen Sustainable Products	张斌, 连云港杜钟新奥神氨纶有限公司 Zhang Bin, LDZ New Aoshen Spandex Co Ltd
17:15 - 17:30 8.2-H128	循环再生 致“净”未来 Recycling to "Clean" Future	刘辉, 唐山三友集团兴达化纤有限公司 Liu Hui, Tangshan Sanyou Group Xingda Chemical Fibre Co Ltd

\* 普通话 Mandarin